

## GIM700DR - 2-dimensional

 2-dimensional, measuring range  $\pm 90^\circ$ 

CANopen® / SAE J1939

### Overview

- High measurement accuracy in dynamic applications
- Rugged housing for tough environment
- Interface CANopen®, SAE J1939
- Connection 2 x M12
- E1 compliant design
- Protection up to IP 69K
- Corrosion protection CX (C5-M)



### Technical data

#### Technical data - electrical ratings

Voltage supply	8...36 VDC
Reverse polarity protection	Yes
Short-circuit proof	Yes
Consumption w/o load	$\leq 30$ mA (24 VDC)
Initializing time	$\leq 1$ s after power on
Interface	CANopen® SAE J1939
Measuring range	$\pm 90^\circ$ (inclination sensor, $\pm 180^\circ$ on request) $\pm 6$ g (accelerometer, triaxial) $\pm 250^\circ/\text{s}$ (gyroscope, triaxial, Z-axis) $125^\circ/\text{s}$
Resolution	$0.01^\circ$ (configurable, Default: $0.1^\circ$ )
Dynamic accuracy typ.	$\pm 0.5^\circ$ (see general information)
Static accuracy typ.	$\pm 0.3^\circ$ ( $+25^\circ\text{C}$ )
Temperature coefficient	Typ. $\leq \pm 0.01^\circ/\text{K}$ (zero position)
Sensing rate	100 Hz
Limit frequency	1...30 Hz / low pass filter up to 6th order (configurable, gyroscope also bandpass)
Load dump protection	ISO 16750-2 for 12 V/24 V systems Pulse 5b (test criteria A)
Interference immunity	EN 61000-6-2 ISO 11452-2:2004* ISO 7637-2:2004* ISO 10605:2008 + Amd 1:2014 (CD $\pm 8$ kV / AD $\pm 15$ kV) * Severity level according to ECE R10 (Rev. 5)

#### Technical data - electrical ratings

Emitted interference	EN 61000-6-4 CISPR 25:2008 (30...1000 MHz) ISO 7637-2:2004* * Severity level according to ECE R10 (Rev. 5)
Approval	CE

#### Technical data - mechanical design

Dimensions W x H x L	77 x 62 x 27 mm
Protection EN 60529	IP 67 IP 68 IP 69K (ISO 20653)
Material	Housing: polyamide (glass fiber reinforced), Aluminium coated
Corrosion protection	EN 60068-2-52 Salt mist for ambient conditions CX (C5-M) according to ISO 12944-2
Operating temperature	$-40 \dots +85^\circ\text{C}$ (see general information)
Resistance	EN 60068-2-6 Vibration 20 g, 60-2000 Hz EN 60068-2-27 Shock 200 g, 6 ms
Temperature changes	EN 60068-2-14, $-40 \dots +85^\circ\text{C}$ , 5 cycles
Weight approx.	134 g
Connection	Flange connector M12, 5-pin

### Optional

- Connection with DEUTSCH or AMP connector on cable end (upon request)

## GIM700DR - 2-dimensional

2-dimensional, measuring range  $\pm 90^\circ$ 

CANopen® / SAE J1939

### General information

Self-heating correlated to installation and ambient conditions as well as to electronics and supply voltage must be considered for precise thermal dimensioning. The inclination sensor is supposed to self-heat to approximately 5 K when attached to a varnished ground metal. Operating the inclination sensor close to the maximum limits requires measuring the currently prevailing temperature at the housing. During initialization, the tilt sensor should be in rest position to get a good angle measurement. Dynamic accuracy might depend on characteristics of movement in application.

### Description

The motion-compensated GIM700DR inclination sensors set new standards in terms of signal quality and response time especially in dynamic applications. Thanks to sensor data fusion of 6-degree-of-freedom MEMS sensors for acceleration and gyroscope, they are extremely responsive and precise, especially when external accelerations are involved. The rugged design offers highest availability under harshest environmental conditions.

Highest precision in dynamic applications

- Uniaxial and biaxial inclination measurement with compensation of external accelerations
- High signal quality and fast response time due to powerful, field-proven sensor fusion algorithms
- Six-degree-of-freedom inertial measurement unit (IMU)
- Output of raw data for acceleration and rotation rate for additional applications

# GIM700DR - 2-dimensional

2-dimensional, measuring range  $\pm 90^\circ$

CANopen® / SAE J1939

## Installation position



### Horizontal installation

When installing the 2-dimensional inclination sensor with the housing in horizontal position, make sure that the base plate is aligned parallel to the horizontal plane.

The sensor can be inclined both towards the X- and the Y-axis. There is one measured value supplied for each axis. Sensor default is 2-dimensional measuring within the selected range, e.g.  $\pm 90^\circ$ . Zero-crossing is exactly in the horizontal plane.

The default position is  $0^\circ$  as shown in the following illustration, and may be user configured via CANopen® and SAE J1939.

Y-axis  $0^\circ$



Y-axis  $-30^\circ$



X-axis  $0^\circ$



X-axis  $+30^\circ$

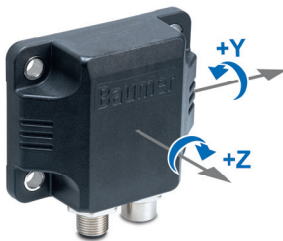

### Vertical installation

When installing the 2-dimensional inclination sensor with the housing in vertical position, make sure that the base plate is aligned parallel to the vertical plane.

The sensor can be inclined both towards the Z- and the Y-axis. There is one measured value supplied for each axis. Sensor default is 2-dimensional measuring within the selected range, e.g.  $\pm 90^\circ$ . Zero-crossing is exactly in the vertical plane.

The default position is  $0^\circ$  as shown in the following illustration, and may be user configured via CANopen® and SAE J1939.

Y-axis  $0^\circ$



Y-axis  $-30^\circ$



Z-axis  $0^\circ$



Z-axis  $+30^\circ$

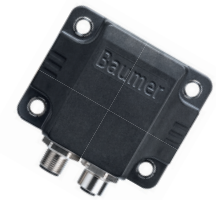

## Terminal assignment

### CANopen® / SAE J1939 – 2xM12 flange connector, 5-pin

Pin	Assignment	Description
1	CAN_GND	Ground connection relating to CAN
2	+Vs	Voltage supply
3	GND	Ground connection relating to +Vs
4	CAN_H	CAN Bus Signal (dominant High)
5	CAN_L	CAN Bus Signal (dominant Low)

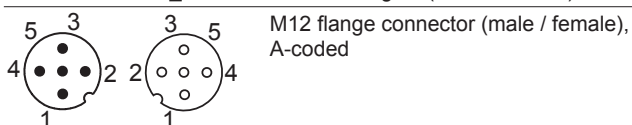

Terminals of the same significance are internally connected and identical in their functions. Max. load on the internal terminal connections Vs-Vs and GND-GND is 0.6 A each.

## CANopen® features

Bus protocol	CANopen®
Device profile	CANopen® - CiA DSP 301 V4.2 Inclinometer profile DS 410 V1.3 LSS service profile DS 305 V2.2
Operating mode	Timer-driven (event-time) Synchronously triggered (Sync)
Address setting	0...127 (default Node ID 1)
Data transmission rate	20...1000 kbit/s (default 50 kbit/s)
Bus termination	Via external terminator
Programmable parameters	Preset Zero position Inverting of counting direction Dynamic PDO Mapping

## GIM700DR - 2-dimensional

2-dimensional, measuring range  $\pm 90^\circ$

CANopen® / SAE J1939

### Dimensions

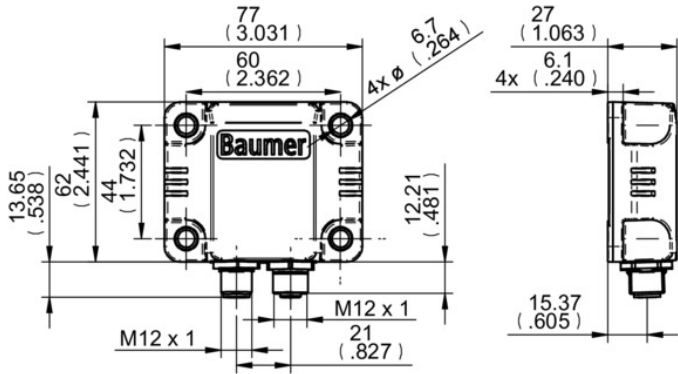

# GIM700DR - 2-dimensional

 2-dimensional, measuring range  $\pm 90^\circ$ 

CANopen® / SAE J1939

**Ordering reference**

	GIM700DR	-	D	N	#	90	.	B	##	.	A
<b>Product</b>	GIM700DR										
<b>Type</b>	GIM700DR										
Dynamic performance	D										
<b>Housing</b>	GIM700DR										
Plastic reinforced / Metal	N										
<b>Number of axes</b>	GIM700DR										
2-dimensional, housing horizontal	2										
2-dimensional, housing vertical	V										
<b>Measuring range</b>	GIM700DR										
$\pm 90^\circ$	90										
<b>Connection</b>	GIM700DR										
Flange connector 2xM12, 5-pin, male and female contacts	B										
<b>Voltage supply / interface</b>	GIM700DR										
8...36 VDC / CANopen®	C6										
8...36 VDC / SAE J1939	C9										
<b>Operating temperature</b>	GIM700DR										
-40...+85 °C	A										

A