

Operating Instructions
for
Thermal Energy Flowmeter
for gases

Model: KEC-1



I. Foreword

Dear customer,

thank you very much for deciding in favour of the KEC-1. Please read this installation and operation manual carefully before mounting and initiating the device and follow our advice. A riskless operation and a correct functioning of the KEC-1 are only guaranteed in case of careful observation of the described instructions and notes.



The instruction manuals on our website www.kobold.com are always for currently manufactured version of our products. Due to technical changes, the instruction manuals available online may not always correspond to the product version you have purchased. If you need an instruction manual that corresponds to the purchased product version, you can request it from us free of charge by email (info.de@kobold.com) in PDF format, specifying the relevant invoice number and serial number. If you wish, the operating instructions can also be sent to you by post in paper form against an applicable postage fee.

Manufactured and sold by:

Kobold Messring GmbH
Nordring 22-24
D-65719 Hofheim
Tel.: +49(0)6192-2990
Fax: +49(0)6192-23398
E-Mail: info.de@kobold.com
Internet: www.kobold.com

II. Table of Content

I.	Foreword	2
II.	Table of Content.....	3
1	Pictograms and Symbols	5
2	Signalwords according ISO 3864 and ANSI Z 535	5
3	Safety instructions	6
3.1	Intended Use	7
3.2	Installation and commissioning.....	7
4	Technical data	8
4.1	Signal circuits.....	9
4.1.1	Modbus	9
4.1.2	Current output.....	9
4.1.2.1	Aktive	9
4.1.2.2	Passive	9
4.1.3	Pulse.....	9
4.1.4	Alarm	9
4.2	Measuring range flow KEC-1.....	10
4.2.1	Measuring range "Low Speed"	11
4.2.2	Measuring range „Standard Version“	12
4.2.3	Measuring range „Max Version“	13
4.2.4	Measuring range „High Speed Version“	14
5	Dimensions.....	15
5.1	Dimension KEC-1	15
6	Installation	16
6.1	Pipe/tube requirements	16
6.2	Inlet / outlet runs	16
6.3	Installation KEC-1	17
6.3.1	½" welded nipple with ball valve ½"	17
6.4	Installation of the Sensor	17
6.4.1	Mounting KEC-1 onto the ball valve	17
6.5	Alignment Display (Housing)	19
6.6	Tightening torques	19
7	Connection diagram	19
7.1	Cable glands - clamping ranges.....	19
7.2	Connector pin assignment.....	20
7.3	Wire connection.....	21
7.3.1	General:	21
7.3.2	Power supply	21
7.3.3	Modbus (termination):.....	21
7.3.4	Pulse Output.....	22
8	Operation KEC-1	23

Table of Content

8.1	Main menu (Home).....	24
8.1.1	Intialization.....	24
8.2	Main menu.....	24
8.3	Settings.....	25
8.3.1	Sensor Setup.....	26
8.3.1.1	Input / change tube diameter.....	26
8.3.1.2	Input / change consumption counter.....	27
8.3.1.3	Definition of the units for flow, velocity, temperature and pressure.....	27
8.3.1.4	Definition of the reference conditions.....	28
8.3.1.5	Setting of Zeropoint and Low-flow cut off.....	30
8.3.2	Modbus Setup.....	31
8.3.2.1	Modbus Settings (2001...2005).....	32
8.3.2.2	Values Register (1001 ...1500).....	32
8.3.3	Pulse /Alarm.....	34
8.3.3.1	Pulse output.....	34
8.3.4	User Setup.....	35
8.3.5	Advanced.....	36
8.3.6	4 -20mA.....	37
8.3.7	KEC-1 Info.....	39
8.4	MBus.....	39
8.4.1	Default Settings communication.....	39
8.4.2	Default values transmitted.....	39
9	EU Declaration of Conformance.....	40

1 Pictograms and Symbols



General Warning symbol (Danger, Warning, Caution)



General note



Installation- and Instruction manual to consider (on Nameplate)



Installation- and Instruction manual to consider

2 Signalwords according ISO 3864 and ANSI Z 535

Danger!	Imminent danger As a consequence of incorrect handling: serious personal injury or death
Warning!	Possible hazard As a consequence of incorrect handling: possible serious injury or death
Caution!	Imminent hazard As a consequence of incorrect handling: possible personal injury or damage
Note!	Possible hazard As a consequence of incorrect handling: possible personal injury or damage
Important!	Additional notes, information, tips As a consequence of incorrect handling: Disadvantages in operation and maintenance, no danger

3 Safety instructions



Please check whether this manual corresponds with the device type.

Please attend to all notes indicated in this instruction manual. It contains essential information, which has to be followed during installation, operation and maintenance. Therefore, this instruction manual has to be read categorically by the technician as well as by the responsible user/qualified personnel before installation, initiation and maintenance

Regional and national regulations respectively, have to be observed in addition to this instruction manual if necessary.

This instruction manual has to be available at any time at the operation site of the KEC-1.

Ensure that the KEC-1 operates within the permissible and listed limits on the nameplate. Otherwise there is a risk to human and material, and it may occur functional and operational disturbances

In case of any obscurities or questions with regard to this manual or the instrument please contact Kobold GmbH.



Warning!

Risk of injury in case of inadequate qualification!

Improper handling can result in significant personal injury and damage.

All activities described in this operating instruction manual must be carried out only by qualified personnel qualifications described below.

Professionals (Technical staff)

The technical staff is based on his education/training, his knowledge of measurement and control technology as well of the local regulations, standards and guidelines in the position to do the work as described and to identify the possible hazards.

Special working conditions require further appropriate knowledge, e.g. of aggressive media.



Caution!

Malfunction of KEC-1

Faulty installation and insufficient maintenance may lead to malfunctions of the KEC-1 which may affect the display and open to misinterpretation.



Danger!

Inadmissible operating parameters!

By exceeding or falling short of limits there is a risk for people and material, in addition there may occur further functional and operational disturbances.

Measures:

- Make sure that the KEC-1 operates only within the permissible and listed limits on the nameplate
- Ensure the operation within the performance data of KEC-1 in connection with the application
- Do not exceed the admissible storage and transportation temperature.

Additional safety information:

- When installing and operating the relevant national regulations and safety rules must also be observed.

3.1 Intended Use

The instrument described in this manual is exclusively to use for measuring the thermal mass flow of gases. At the same time, the gas temperature is measured too.

The KEC-1 can be configured for measuring a predetermined range of pure gases or of gas mixtures.

Consumption measurement of gases such as Air, oxygen, nitrogen, carbon dioxide, argon, etc.

Improper or incorrect use the operational reliability will be canceled. The manufacturer is not liable for any damage resulting by improper or incorrect use.

3.2 Installation and commissioning

- Installation, electrical installation, commissioning, operation and maintenance of the device must only be carried by qualified personnel, which were authorized by the plant operator. The personnel must read the operating instructions and understand and follow their instructions.
- If carrying out welding work on the pipeline the grounding of the welding unit is not allowed to be done over the KEC-1 itself.
- The installer has to ensure that the KEC-1 is connected according to the electrical connection diagrams properly. The sensor must be grounded, unless special protective measures have been taken (e.g. galvanically isolated power supply)
- The existing/ applicable national regulations governing opening and repair of the device have to be applied.
- The device fulfills the general safety requirements in accordance with EN 61010-1, the EMC requirements of IEC / EN 61326 and NAMUR recommendation NE 43.

4 Technical data

Measures:	mass flow, consumption flow speed, temperature
Measuring principle:	thermal mass flow sensor
Medium temperature range:	-40 ... 180 °C Probe -20 ... 120 ° C for medium oxygen, natural gas, propane, methane, biogas and/or in conjunction with silicone-free design
Operating temperature range:	-20 ... 70 °C
Operating pressure:	50 bar
Power supply:	18 ... 36 VDC
Power consumption:	max. 5 W
Output:	Modbus RTU (acc. EIA/TIA-485 Standard) 2 x 4...20 mA active (optional passive) RL < 500 Ohm galvanically isolated pulse (Pulse weight freely selectable, Alarm max. 48 Vdc 0.5 A, optional: HART, ProfibusDP, Profi Net,
Accuracy: Standard version* (m.v. of meas. value) (f.s. of full scale)	± 1.5 % m.v. ± 0.3 % f.s.
Accuracy: Precision version* (m.v. of meas. value) (f.s. of full scale)	± 1.0 % m.v. ± 0.3 % f.s.
Repeatability:	0.25% m.v in case of correct mounting (mounting aid, position, inlet section)
Accuracy indications:	referred to ambient temperature 22 °C +/-2 °C, system pressure 6 bar
Response time:	t90 < 3 s
Display:	2" TFT Color Display (320 x 240)
Screw in thread:	G 1/2" ISO 228, NPT 1/2", R 1/2", PT 1/2"
Material:	Housing aluminum die cast, probe stainless steel 1,4571
Protection class	IP67

* Reference conditions for Temperature and pressure can be freely set, standard conditions are 0 ° and 1013 mbar.

4.1 Signal circuits

4.1.1 Modbus

- According Standard EIA/TIA-485

4.1.2 Current output

4.1.2.1 Aktive

- Galvanically isolated
- 4 ... 20 mA
- $R_L < 500 \text{ Ohm}$

4.1.2.2 Passive

- Galvanically isolated
- 4 ... 20 mA
- $R_L < 500 \text{ Ohm}$
- $V_{in} 12\text{-}36 \text{ Vdc}$

4.1.3 Pulse

- Galvanically isolated (dry contact)
- Passive: 48 Vdc , 500 mA
- Max. pulse output freq. 50 Hz

4.1.4 Alarm

- Galvanically isolated
- Max. 48 Vdc, 500 mA

4.2 Measuring range flow KEC-1

The flow-/consumption sensor KEC-1 is available in 3 different versions:

- Low Speed Version max. measuring range of 50 m/s
- Standard max. measuring range of 92.7 m/s
- Max-Version max. measuring range of 185.0 m/s
- High speed-Version max. measuring range of 224 m/s

The sensors are programmed to pipe inner diameter of 53,1 mm this corresponds to analogue output 4- 20 mA of:

	Measuring range	Analogue output scaling
• Low Speed	0...323.6 m ³ /h	4 mA = 0 m ³ h, 20 mA = 323.6 m ³ /h
• Standard	0 ... 600 m ³ /h	4 mA = 0 m ³ h, 20 mA = 600 m ³ /h
• Max-Version	0 ... 1197.59 m ³ /h	4 mA = 0 m ³ h, 20 mA = 1197.59 m ³ /h
• Highspeed-Version	0 ... 1450.06 m ³ /h	4 mA = 0 m ³ h, 20 mA = 1450.06 m ³ /h

In case of use in other inner pipe diameter the diameter, using the display version, the diameter has to be set first.

For changing the inner pipe diameter and adjusting the 4...20 mA scaling, please refer to chapter "Operation".

The corresponding scale values for the respective version could be found in sections 4.2.1 to 4.2.3.

Example:

Pipe 1", Inner diameter 25mm

	Measuring range	Analogue output scaling
• Low Speed	0 ... 65.9 m ³ /h	4 mA = 0 m ³ h, 20 mA = 65.9 m ³ /h
• Standard Version	0 ... 122.2 m ³ /h	4 mA = 0 m ³ h, 20 mA = 122.2 m ³ /h
• Max-Version	0 ... 243.88 m ³ /h	4 mA = 0 m ³ h, 20 mA = 243.88 m ³ /h
• Highspeed-Version	0 ... 295.30 m ³ /h	4 mA = 0 m ³ h, 20 mA = 295.30 m ³ /h

4.2.1 Measuring range “Low Speed”

Measuring ranges low-speed version

Inside diameter of pipe			Low-speed version (50 m/s)									Recomm- ended probe length
			Measuring range full scales in Nm ³ /h* / [cfm]									
Inch	mm	DN	Air**	Nitrogen (N ₂)	Argon (Ar)	Oxygen (O ₂)	Carbon dioxide (CO ₂)	Methane natural gas (CH ₄)	Helium (He)	Hydrogen (H ₂)	Propane (C ₃ H ₈)	
½"	16.1	DN 15	24 [14]	22 [13]	38 [22]	23 [13]	24 [14]	14 [8]	10 [6]	7 [4]	11 [6]	160 mm - 6.299 inch
¾"	21.7	DN 20	48 [28]	44 [26]	75 [44]	45 [26]	47 [27]	28 [16]	20 [11]	14 [8]	22 [13]	
1"	27.3	DN 25	79 [46]	73 [43]	124 [73]	75 [44]	78 [46]	47 [27]	33 [19]	23 [13]	36 [21]	
1¼"	36.0	DN 32	143 [84]	132 [77]	224 [132]	136 [80]	142 [83]	85 [50]	60 [35]	42 [24]	66 [38]	
1½"	41.9	DN 40	197 [116]	181 [107]	309 [182]	188 [111]	195 [115]	117 [68]	82 [48]	58 [34]	90 [53]	
2"	53.1	DN 50	323 [190]	297 [175]	506 [297]	308 [181]	320 [188]	191 [112]	135 [79]	95 [55]	148 [87]	
2½"	68.9	DN 65	554 [326]	509 [300]	866 [510]	528 [311]	548 [322]	328 [193]	231 [136]	162 [95]	254 [150]	220 mm - 8.661 inch
3"	80.9	DN 80	768 [452]	706 [415]	1201 [706]	732 [431]	760 [447]	454 [267]	321 [188]	225 [132]	353 [207]	
4"	110.0	DN 100	1426 [839]	1311 [772]	2230 [1312]	1360 [800]	1411 [830]	844 [496]	596 [350]	418 [246]	655 [386]	
5"	133.7	DN 125	2110 [1241]	1940 [1141]	3299 [1941]	2011 [1183]	2088 [1228]	1248 [734]	881 [519]	619 [364]	970 [570]	
6"	159.3	DN 150	2999 [1765]	2758 [1623]	4689 [2759]	2859 [1682]	2967 [1746]	1774 [1044]	1253 [737]	880 [518]	1379 [811]	300 mm - 11.811 inch
8"	200.0	DN 200	4738 [2788]	4357 [2564]	7409 [4360]	4517 [2658]	4689 [2759]	2804 [1650]	1980 [1165]	1391 [819]	2178 [1282]	
10"	250.0	DN 250	7413 [4362]	6817 [4011]	11590 [6820]	7067 [4159]	7336 [4317]	4386 [2581]	3098 [1823]	2177 [1281]	3408 [2005]	
12"	300.0	DN 300	10687 [6289]	9828 [5783]	16710 [9833]	10189 [5996]	10576 [6224]	6324 [3721]	4466 [2628]	3138 [1847]	4914 [2891]	

Measuring ranges low-speed version (continued)

Inside diameter of pipe			Low-speed version (50 m/s)									Recomm- ended probe length
			Measuring range full scales in Nm ³ /h* / [cfm]									
Inch	mm	DN	Corgon @18	Forming gas 90% N ₂ + 10% H ₂	Natural gas (NG)	Biogas 50% CH ₄ + 50% CO ₂	Biogas 60% CH ₄ + 40% CO ₂	LPG 60% C ₃ H ₈ + 40% C ₄ H ₁₀	LPG 50% C ₃ H ₈ + 50% C ₄ H ₁₀	Nitrous oxide (N ₂ O)	Ethyne/ Acetylene (C ₂ H ₂)	
½"	16.1	DN 15	35 [21]	20 [12]	15 [9]	17 [10]	17 [10]	13 [7]	12 [7]	24 [14]	13 [8]	160 mm - 6.299 inch
¾"	21.7	DN 20	70 [41]	40 [23]	30 [17]	34 [20]	34 [20]	25 [15]	25 [14]	47 [27]	26 [15]	
1"	27.3	DN 25	116 [68]	67 [39]	50 [29]	57 [34]	56 [33]	42 [24]	41 [24]	78 [45]	44 [26]	
1¼"	36.0	DN 32	209 [123]	121 [71]	91 [53]	104 [61]	101 [59]	76 [45]	74 [44]	140 [89]	80 [47]	
1½"	41.9	DN 40	288 [170]	167 [98]	125 [73]	143 [84]	140 [82]	105 [62]	103 [60]	194 [114]	110 [65]	
2"	53.1	DN 50	472 [278]	273 [161]	205 [120]	235 [138]	229 [135]	172 [101]	168 [99]	317 [186]	181 [106]	
2½"	68.9	DN 65	809 [476]	469 [276]	351 [207]	403 [237]	393 [231]	295 [173]	288 [169]	543 [320]	311 [183]	220 mm - 8.661 inch
3"	80.9	DN 80	1121 [660]	649 [382]	487 [286]	558 [328]	544 [320]	409 [240]	400 [235]	753 [443]	430 [253]	
4"	110.0	DN 100	2082 [1225]	1206 [710]	905 [532]	1037 [610]	1011 [595]	759 [447]	742 [437]	1399 [823]	800 [470]	
5"	133.7	DN 125	3080 [1813]	1785 [1050]	1338 [787]	1534 [903]	1496 [880]	1123 [661]	1098 [646]	2069 [1217]	1183 [696]	
6"	159.3	DN 150	4378 [2576]	2537 [1493]	1903 [1119]	2181 [1283]	2126 [1251]	1597 [939]	1561 [919]	2941 [1731]	1682 [990]	300 mm - 11.811 inch
8"	200.0	DN 200	6918 [4071]	4009 [2359]	3006 [1769]	3446 [2028]	3359 [1977]	2523 [1485]	2467 [1452]	4647 [2735]	2658 [1564]	
10"	250.0	DN 250	10823 [6369]	6271 [3690]	4703 [2768]	5392 [3173]	5255 [3093]	3947 [2323]	3860 [2271]	7270 [4278]	4158 [2447]	
12"	300.0	DN 300	15604 [9183]	9042 [5321]	6781 [3990]	7774 [4575]	7577 [4459]	5691 [3349]	5565 [3275]	10482 [6168]	5995 [3528]	

* Nm³/h in acc. with DIN 1343: 0 °C, 1013.25 hPa for gases

** ISO 1217: 20 °C, 1000 hPa for air

4.2.2 Measuring range „Standard Version“

Measuring ranges standard version

Inside diameter of pipe			Standard version (92.7 m/s)									Recomm- ended probe length
			Measuring range full scales in Nm ³ /h* / [cfm]									
Inch	mm	DN	Air**	Nitrogen (N ₂)	Argon (Ar)	Oxygen (O ₂)	Carbon dioxide (CO ₂)	Methane natural gas (CH ₄)	Helium (He)	Hydrogen (H ₂)	Propane (C ₃ H ₈)	
½"	16.1	DN 15	45 [26]	41 [24]	71 [41]	43 [25]	45 [26]	26 [15]	19 [11]	13 [7]	20 [12]	160 mm - 6.299 inch
¾"	21.7	DN 20	89 [52]	81 [48]	139 [81]	84 [49]	88 [51]	52 [31]	37 [21]	26 [15]	40 [24]	
1"	27.3	DN 25	147 [86]	135 [79]	230 [135]	140 [82]	146 [86]	87 [51]	61 [36]	43 [25]	67 [39]	
1 ¼"	36.0	DN 32	266 [156]	244 [144]	416 [245]	253 [149]	263 [155]	157 [92]	111 [65]	78 [46]	122 [72]	
1 ½"	41.9	DN 40	366 [215]	337 [198]	573 [337]	349 [205]	363 [213]	217 [127]	153 [90]	107 [63]	168 [99]	
2"	53.1	DN 50	600 [353]	551 [324]	938 [552]	572 [336]	593 [349]	355 [208]	250 [147]	176 [103]	275 [162]	220 mm - 8.661 inch
2 ½"	68.9	DN 65	1028 [604]	945 [556]	1607 [945]	980 [576]	1017 [598]	608 [358]	429 [252]	301 [177]	472 [278]	
3"	80.9	DN 80	1424 [838]	1309 [770]	2227 [1310]	1358 [799]	1409 [829]	842 [496]	595 [350]	418 [246]	654 [385]	
4"	110.0	DN 100	2644 [1556]	2432 [1431]	4135 [2433]	2521 [1484]	2617 [1540]	1565 [921]	1105 [650]	776 [457]	1216 [715]	
5"	133.7	DN 125	3912 [2302]	3597 [2117]	6116 [3599]	3729 [2195]	3871 [2278]	2315 [1362]	1635 [962]	1149 [676]	1798 [1058]	
6"	159.3	DN 150	5560 [3272]	5113 [3009]	8693 [5116]	5301 [3119]	5502 [3238]	3290 [1936]	2324 [1367]	1633 [961]	2556 [1504]	300 mm - 11.811 inch
8"	200.0	DN 200	8785 [5170]	8079 [4754]	13736 [8083]	8376 [4929]	8694 [5116]	5198 [3059]	3672 [2160]	2580 [1518]	4039 [2377]	
10"	250.0	DN 250	13744 [8088]	12638 [7437]	21488 [12646]	13103 [7711]	13601 [8004]	8133 [4786]	5744 [3380]	4036 [2375]	6319 [3718]	
12"	300.0	DN 300	19814 [11661]	18221 [10723]	30980 [18232]	18891 [11117]	19609 [11539]	11725 [6900]	8281 [4873]	5819 [3424]	9110 [5361]	

Measuring ranges standard version (continued)

Inside diameter of pipe			Standard version (92.7 m/s)									Recomm- ended probe length
			Measuring range full scales in Nm ³ /h* / [cfm]									
Inch	mm	DN	Corgon ®18	Forming gas 90% N ₂ + 10% H ₂	Natural gas (NG)	Biogas 50% CH ₄ + 50% CO ₂	Biogas 60% CH ₄ + 40% CO ₂	LPG 60% C ₃ H ₈ + 40% C ₄ H ₁₀	LPG 50% C ₃ H ₈ + 50% C ₄ H ₁₀	Nitrous oxide (N ₂ O)	Ethyne/ Acetylene (C ₂ H ₂)	
½"	16.1	DN 15	66 [39]	38 [22]	28 [17]	33 [19]	32 [19]	24 [14]	23 [13]	44 [26]	25 [15]	160 mm - 6.299 inch
¾"	21.7	DN 20	130 [76]	75 [44]	56 [33]	64 [38]	63 [37]	47 [27]	46 [27]	87 [51]	49 [29]	
1"	27.3	DN 25	215 [126]	124 [73]	93 [55]	107 [63]	104 [61]	78 [46]	76 [45]	144 [85]	82 [48]	
1 ¼"	36.0	DN 32	388 [228]	225 [132]	168 [99]	193 [114]	188 [111]	141 [83]	138 [81]	261 [153]	149 [87]	
1 ½"	41.9	DN 40	535 [315]	310 [182]	232 [136]	266 [157]	260 [153]	195 [114]	191 [112]	359 [211]	205 [121]	
2"	53.1	DN 50	876 [515]	507 [298]	380 [224]	436 [256]	425 [250]	319 [188]	312 [183]	588 [346]	336 [198]	220 mm - 8.661 inch
2 ½"	68.9	DN 65	1500 [883]	869 [511]	652 [383]	747 [440]	728 [428]	547 [322]	535 [315]	1008 [593]	576 [339]	
3"	80.9	DN 80	2079 [1223]	1205 [709]	903 [531]	1036 [609]	1009 [594]	758 [446]	741 [436]	1397 [822]	799 [470]	
4"	110.0	DN 100	3861 [2272]	2237 [1316]	1678 [987]	1923 [1132]	1875 [1103]	1408 [828]	1377 [810]	2594 [1526]	1483 [873]	
5"	133.7	DN 125	5711 [3361]	3309 [1947]	2482 [1460]	2845 [1674]	2773 [1632]	2083 [1226]	2037 [1198]	3837 [2258]	2194 [1291]	
6"	159.3	DN 150	8118 [4777]	4704 [2768]	3528 [2076]	4044 [2380]	3942 [2320]	2961 [1742]	2895 [1704]	5453 [3209]	3119 [1835]	300 mm - 11.811 inch
8"	200.0	DN 200	12827 [7548]	7432 [4374]	5574 [3280]	6390 [3760]	6229 [3665]	4678 [2753]	4575 [2692]	8616 [5071]	4928 [2900]	
10"	250.0	DN 250	20066 [11809]	11627 [6842]	8720 [5132]	9997 [5883]	9744 [5734]	7319 [4307]	7157 [4212]	13480 [7932]	7709 [4537]	
12"	300.0	DN 300	28930 [17025]	16763 [9865]	12572 [7399]	14413 [8482]	14048 [8267]	10552 [6209]	10318 [6072]	19434 [11437]	11115 [6541]	

* Nm³/h in acc. with DIN 1343: 0 °C, 1013.25 hPa for gases

** ISO 1217: 20 °C, 1000 hPa for air

4.2.3 Measuring range „Max Version“

Measuring ranges max version

Inside diameter of pipe			Max version (185.0 m/s)									Recomm- ended probe length
			Measuring range full scales in Nm ³ /h* / [cfm]									
Inch	mm	DN	Air**	Nitrogen (N ₂)	Argon (Ar)	Oxygen (O ₂)	Carbon dioxide (CO ₂)	Methane natural gas (CH ₄)	Helium (He)	Hydrogen (H ₂)	Propane (C ₃ H ₈)	
½"	16.1	DN 15	90 [53]	83 [49]	142 [83]	86 [51]	90 [52]	53 [31]	38 [22]	26 [15]	41 [24]	160 mm - 6.299 inch
¾"	21.7	DN 20	177 [104]	163 [96]	278 [163]	169 [99]	175 [103]	105 [61]	74 [43]	52 [30]	81 [48]	
1"	27.3	DN 25	294 [173]	271 [159]	460 [271]	280 [165]	291 [171]	174 [102]	123 [72]	86 [50]	135 [79]	
1 ¼"	36.0	DN 32	531 [312]	488 [287]	830 [489]	506 [298]	525 [309]	314 [185]	222 [130]	156 [91]	244 [143]	
1 ½"	41.9	DN 40	732 [430]	673 [396]	1144 [673]	697 [410]	724 [426]	433 [254]	305 [180]	215 [126]	336 [198]	
2"	53.1	DN 50	1197 [704]	1101 [648]	1872 [1101]	1141 [671]	1185 [697]	708 [417]	500 [294]	351 [206]	550 [324]	
2 ½"	68.9	DN 65	2051 [1207]	1886 [1110]	3207 [1887]	1955 [1151]	2030 [1194]	1214 [714]	857 [504]	602 [354]	943 [555]	220 mm - 8.661 inch
3"	80.9	DN 80	2842 [1672]	2614 [1538]	4444 [2615]	2710 [1594]	2813 [1655]	1682 [989]	1188 [699]	834 [491]	1307 [769]	
4"	110.0	DN 100	5278 [3106]	4854 [2856]	8252 [4856]	5032 [2961]	5223 [3074]	3123 [1838]	2206 [1298]	1550 [912]	2427 [1428]	
5"	133.7	DN 125	7807 [4594]	7179 [4225]	12206 [7183]	7443 [4380]	7726 [4546]	4620 [2718]	3263 [1920]	2293 [1349]	3589 [2112]	
6"	159.3	DN 150	11096 [6530]	10204 [6005]	17349 [10210]	10579 [6226]	10981 [6462]	6566 [3864]	4637 [2729]	3259 [1917]	5102 [3002]	300 mm - 11.811 inch
8"	200.0	DN 200	17533 [10318]	16123 [9488]	27413 [16132]	16716 [9837]	17351 [10211]	10375 [6105]	7328 [4312]	5149 [3030]	8061 [4744]	
10"	250.0	DN 250	27428 [16141]	25223 [14843]	42884 [25237]	26150 [15389]	27143 [15974]	16231 [9552]	11463 [6746]	8055 [4740]	12611 [7421]	
12"	300.0	DN 300	39544 [23271]	36364 [21400]	61827 [36385]	37701 [22187]	39133 [23030]	23400 [13771]	16527 [9726]	11614 [6834]	18182 [10700]	

Measuring ranges max version (continued)

Inside diameter of pipe			Max version (185.0 m/s)									Recomm- ended probe length
			Measuring range full scales in Nm ³ /h* / [cfm]									
Inch	mm	DN	Corgon @18	Forming gas 90% N ₂ + 10% H ₂	Natural gas (NG)	Biogas 50% CH ₄ + 50% CO ₂	Biogas 60% CH ₄ + 40% CO ₂	LPG 60% C ₃ H ₈ + 40% C ₄ H ₁₀	LPG 50% C ₃ H ₈ + 50% C ₄ H ₁₀	Nitrous oxide (N ₂ O)	Ethyne/ Acetylene (C ₂ H ₂)	
½"	16.1	DN 15	132 [78]	76 [45]	57 [33]	66 [38]	64 [37]	48 [28]	47 [27]	89 [52]	51 [30]	160 mm - 6.299 inch
¾"	21.7	DN 20	259 [152]	150 [88]	112 [66]	129 [76]	126 [74]	94 [55]	92 [54]	174 [102]	99 [58]	
1"	27.3	DN 25	430 [253]	249 [146]	187 [110]	214 [126]	208 [122]	156 [92]	153 [90]	289 [170]	165 [97]	
1 ¼"	36.0	DN 32	775 [456]	449 [264]	337 [198]	386 [227]	376 [221]	283 [166]	276 [162]	521 [306]	298 [175]	
1 ½"	41.9	DN 40	1068 [629]	619 [364]	464 [273]	532 [313]	519 [305]	389 [229]	381 [224]	718 [422]	410 [241]	
2"	53.1	DN 50	1748 [1029]	1013 [596]	759 [447]	871 [512]	849 [499]	637 [375]	623 [367]	1174 [691]	671 [395]	
2 ½"	68.9	DN 65	2995 [1762]	1735 [1021]	1301 [766]	1492 [878]	1454 [856]	1092 [642]	1068 [628]	2012 [1184]	1150 [677]	220 mm - 8.661 inch
3"	80.9	DN 80	4150 [2442]	2404 [1415]	1803 [1061]	2067 [1216]	2015 [1186]	1513 [890]	1480 [871]	2788 [1640]	1594 [938]	
4"	110.0	DN 100	7706 [4535]	4465 [2628]	3349 [1971]	3839 [2259]	3742 [2202]	2811 [1654]	2748 [1617]	5177 [3046]	2961 [1742]	
5"	133.7	DN 125	11399 [6708]	6605 [3887]	4954 [2915]	5679 [3342]	5535 [3257]	4157 [2446]	4065 [2392]	7657 [4506]	4379 [2577]	
6"	159.3	DN 150	16201 [9534]	9388 [5524]	7041 [4143]	8071 [4750]	7867 [4630]	5909 [3477]	5778 [3400]	10883 [6405]	6224 [3663]	300 mm - 11.811 inch
8"	200.0	DN 200	25599 [15065]	14833 [8729]	11125 [6547]	12753 [7505]	12431 [7315]	9337 [5494]	9130 [5373]	17196 [10120]	9835 [5788]	
10"	250.0	DN 250	40046 [23567]	23205 [13656]	17404 [10242]	19951 [11741]	19447 [11444]	14606 [8596]	14283 [8406]	26901 [15831]	15386 [9054]	
12"	300.0	DN 300	57736 [33977]	33455 [19688]	25091 [14766]	28764 [16927]	28037 [16499]	21058 [12393]	20593 [12119]	38784 [22824]	22182 [13054]	

* Nm³/h in acc. with DIN 1343: 0 °C, 1013.25 hPa for gases

** ISO 1217: 20 °C, 1000 hPa for air

4.2.4 Measuring range „High Speed Version“

Measuring ranges high-speed version

Inside diameter of pipe			High-speed version (224.0 m/s)									Recommended probe length
Inch	mm	DN	Measuring range full scales in Nm ³ /h* / [cfm]									
			Air**	Nitrogen (N ₂)	Argon (Ar)	Oxygen (O ₂)	Carbon dioxide (CO ₂)	Methane natural gas (CH ₄)	Helium (He)	Hydrogen (H ₂)	Propane (C ₃ H ₈)	
½"	16.1	DN 15	110 [64]	101 [59]	172 [101]	105 [61]	109 [64]	65 [38]	46 [27]	32 [19]	50 [29]	160 mm - 6.299 inch
¾"	21.7	DN 20	215 [126]	198 [116]	336 [198]	205 [120]	213 [125]	127 [74]	89 [52]	63 [37]	99 [58]	
1"	27.3	DN 25	356 [210]	328 [193]	557 [328]	340 [200]	353 [207]	211 [124]	149 [87]	104 [61]	164 [96]	
1 ¼"	36.0	DN 32	643 [378]	591 [348]	1006 [592]	613 [361]	636 [374]	380 [224]	268 [158]	188 [111]	295 [174]	
1 ½"	41.9	DN 40	886 [521]	815 [479]	1385 [815]	845 [497]	877 [516]	524 [308]	370 [218]	260 [153]	407 [239]	
2"	53.1	DN 50	1450 [853]	1333 [784]	2267 [1334]	1382 [813]	1434 [844]	858 [504]	606 [356]	425 [250]	666 [392]	
2 ½"	68.9	DN 65	2484 [1461]	2284 [1344]	3883 [2285]	2368 [1393]	2458 [1446]	1469 [865]	1038 [611]	729 [429]	1142 [672]	220 mm - 8.661 inch
3"	80.9	DN 80	3441 [2025]	3165 [1862]	5381 [3166]	3281 [1931]	3406 [2004]	2036 [1198]	1438 [846]	1010 [594]	1582 [931]	
4"	110.0	DN 100	6391 [3761]	5877 [3458]	9992 [5880]	6093 [3586]	6324 [3722]	3782 [2225]	2671 [1572]	1877 [1104]	2938 [1729]	
5"	133.7	DN 125	9453 [5563]	8693 [5116]	14780 [8698]	9012 [5304]	9355 [5505]	5594 [3292]	3951 [2325]	2776 [1633]	4346 [2558]	
6"	159.3	DN 150	13436 [7907]	12355 [7271]	21007 [12362]	12810 [7538]	13296 [7825]	7950 [4679]	5615 [3304]	3946 [2322]	6177 [3635]	300 mm - 11.811 inch
8"	200.0	DN 200	21229 [12493]	19522 [11489]	33192 [19533]	20240 [11911]	21009 [12363]	12562 [7393]	8873 [5221]	6235 [3669]	9761 [5744]	
10"	250.0	DN 250	33211 [19544]	30540 [17973]	51925 [30557]	31663 [18633]	32865 [19341]	19652 [11565]	13880 [8168]	9753 [5740]	15270 [8986]	
12"	300.0	DN 300	47880 [28177]	44030 [25912]	74861 [44055]	45649 [26864]	47383 [27885]	28333 [16674]	20012 [11777]	14062 [8275]	22015 [12956]	

Measuring ranges high-speed version (continued)

Inside diameter of pipe			High-speed version (224.0 m/s)									Recommended probe length
Inch	mm	DN	Measuring range full scales in Nm ³ /h* / [cfm]									
			Corgon ®18	Forming gas 90% N ₂ + 10% H ₂	Natural gas (NG)	Biogas 50% CH ₄ + 50% CO ₂	Biogas 60% CH ₄ + 40% CO ₂	LPG 60% C ₂ H ₆ + 40% C ₄ H ₁₀	LPG 50% C ₂ H ₆ + 50% C ₄ H ₁₀	Nitrous oxide (N ₂ O)	Ethyne/ Acetylene (C ₂ H ₂)	
½"	16.1	DN 15	160 [94]	93 [54]	69 [41]	80 [47]	78 [45]	58 [34]	57 [33]	108 [63]	61 [36]	160 mm - 6.299 inch
¾"	21.7	DN 20	314 [185]	182 [107]	136 [80]	156 [92]	152 [89]	114 [67]	112 [65]	211 [124]	120 [71]	
1"	27.3	DN 25	521 [306]	301 [177]	226 [133]	259 [152]	253 [148]	190 [111]	185 [109]	349 [205]	200 [117]	
1 ¼"	36.0	DN 32	939 [552]	544 [320]	408 [240]	468 [275]	456 [268]	342 [201]	335 [197]	631 [371]	360 [212]	
1 ½"	41.9	DN 40	1294 [761]	749 [441]	562 [331]	644 [379]	628 [369]	472 [277]	461 [271]	869 [511]	497 [292]	
2"	53.1	DN 50	2117 [1245]	1226 [721]	920 [541]	1054 [620]	1028 [605]	772 [454]	755 [444]	1422 [836]	813 [478]	
2 ½"	68.9	DN 65	3626 [2134]	2101 [1236]	1576 [927]	1806 [1063]	1761 [1036]	1322 [778]	1293 [761]	2436 [1433]	1393 [820]	220 mm - 8.661 inch
3"	80.9	DN 80	5025 [2957]	2911 [1713]	2183 [1285]	2503 [1473]	2440 [1436]	1832 [1078]	1792 [1054]	3375 [1986]	1930 [1136]	
4"	110.0	DN 100	9331 [5491]	5407 [3182]	4055 [2386]	4649 [2735]	4531 [2666]	3403 [2003]	3328 [1958]	6268 [3689]	3585 [2109]	
5"	133.7	DN 125	13802 [8122]	7997 [4706]	5998 [3530]	6876 [4046]	6702 [3944]	5034 [2962]	4923 [2897]	9271 [5456]	5302 [3120]	
6"	159.3	DN 150	19617 [11544]	11367 [6689]	8525 [5017]	9773 [5751]	9526 [5606]	7155 [4210]	6997 [4117]	13178 [7755]	7537 [4435]	300 mm - 11.811 inch
8"	200.0	DN 200	30996 [18241]	17960 [10569]	13470 [7927]	15442 [9087]	15051 [8858]	11305 [6653]	11055 [6506]	20821 [12253]	11908 [7008]	
10"	250.0	DN 250	48489 [28535]	28097 [16535]	21072 [12401]	24157 [14216]	23546 [13857]	17686 [10408]	17295 [10178]	32573 [19169]	18629 [10963]	
12"	300.0	DN 300	69907 [41140]	40508 [23839]	30381 [17879]	34828 [20496]	33947 [19978]	25498 [15005]	24934 [14674]	46961 [27636]	26858 [15806]	

* Nm³/h in acc. with DIN 1343: 0 °C, 1013.25 hPa for gases

** ISO 1217: 20 °C, 1000 hPa for air

5 Dimensions

5.1 Dimension KEC-1

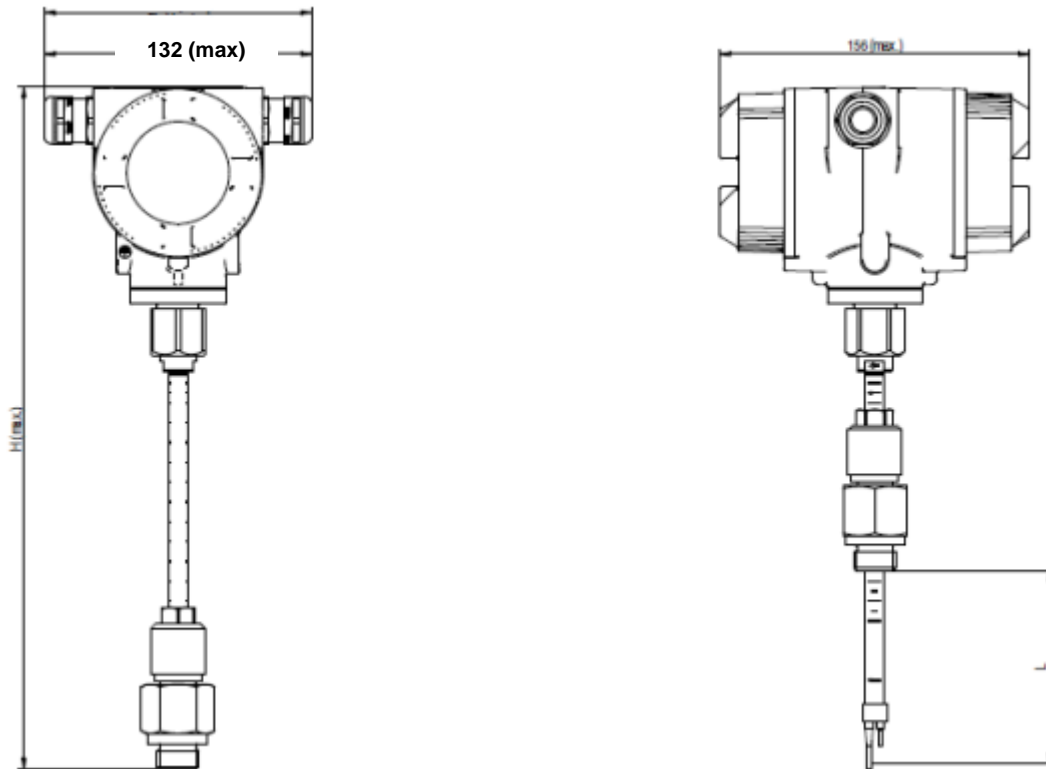

Sensor length	L [mm]	H [mm]
C1	220	441
C2	300	521
C3	400	621
C4	500	721
C5	600	821
C7	160	381

6 Installation

6.1 Pipe/tube requirements

- Correctly sized gaskets
- Correct aligned flanges and gaskets
- Diameter mismatch at the pipe junctions should be avoided but must be less than 1mm. For further information see ISO 14511
- Ensure clean pipes after installation

6.2 Inlet / outlet runs

The principle of thermal Mass flow measurement is very sensitive against disturbances. Therefore, it is necessary to ensure the recommended inlet and outlet runs.

Table Inlet / Outlet runs

Flow obstruction before the measurement section	Min length Inlet run (L1)	Min length Outlet run (L2)
Slight curve (elbow < 90°)	12 x D	5 x D
Reduction (Pipe narrows to the measurement section)	15 x D	5 x D
Expansion (Pipe expands to the measurement section)	15 x D	5 x D
90° elbow or T-piece	15 x D	5 x D
2x elbow á 90° in einer Ebene	20 x D	5 x D
2x elbow á 90° 3-dimensional	35 x D	5 x D
Control valve	45 x D	5 x D

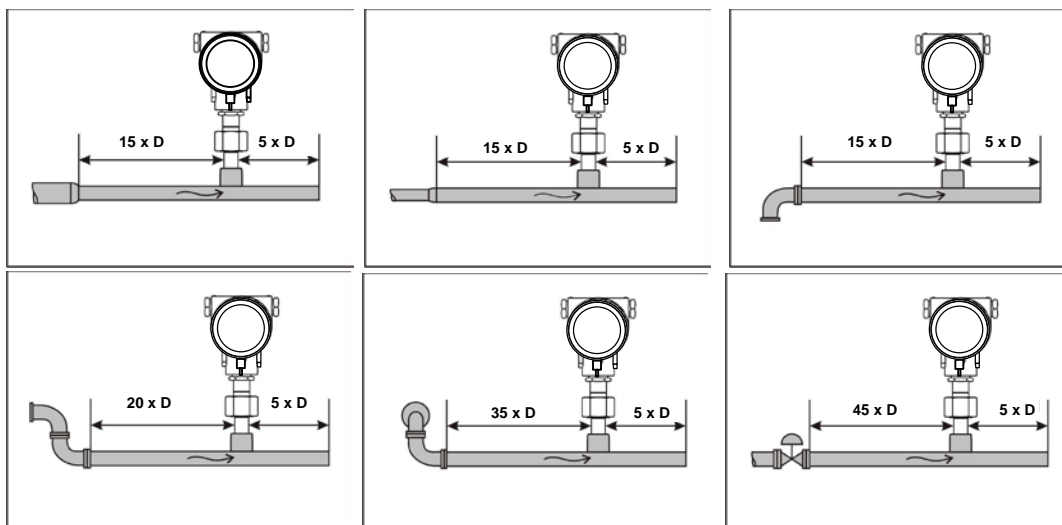

The values represent the min. lengths. In case the min. inlet / outlet runs could not be ensured, it must be expected to get increased or significant deviations of the measurement values.

6.3 Installation KEC-1

The installation of the sensor is done via a ball valve ½ ".

If no valid measuring point with a ball valve ½ " is available there are following ways to set up a measuring point.

6.3.1 ½“ welded nipple with ball valve ½“



Important:

Ensure that the system is in shut down, i.e. depressurized.

Note for installation with ball valve

Ball valve R 1/2“, DN 15

Passage ball valve: Minimum Ø15 mm

6.4 Installation of the Sensor

6.4.1 Mounting KEC-1 onto the ball valve

- Assembly is carried out by inserting the connection thread with gasket. (G1/2“ thread, SW 32) into the connection piece (ball valve). The sensor has to be tighten by hand as far as possible and then tighten with stipulated torque of 25-30 Nm. It must be ensured that the installation is pressure-tight.



- The sensor is then inserted to the required immersion depth and aligned according to the direction of the airflow. A depth scale engraved on the probe tube, a flow alignment arrow and an aligning device will be of help for you. Once the sensor has been aligned the adapter sleeve must be tighten with stipulated torque of 20-30Nm (SW 17).

Attention: Alignment of the sensor must not be modified when tightening the connection thread and adapter sleeve. In this case, please check the immersion depth and alignment again and correct it if necessary. The angular deviation should not be greater than ± 2° in relation to ideal position as otherwise the measuring accuracy will decrease.

Calculation mounting depth:

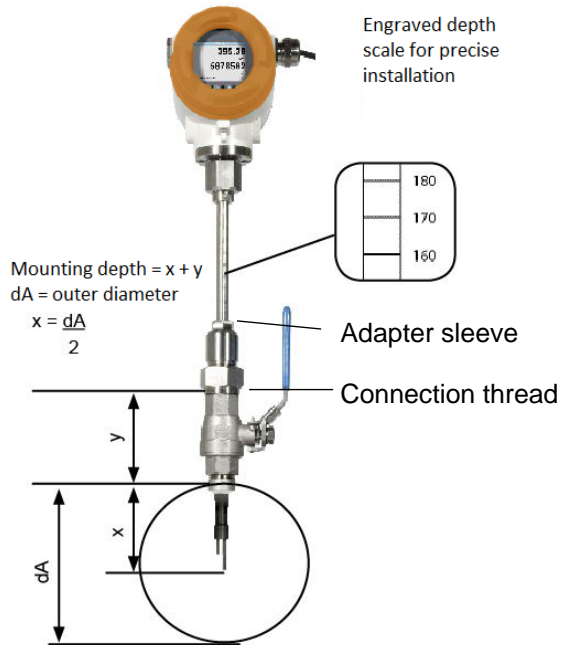

Alignment



Sensor alignment

A max. angle deviation of $\pm 2^\circ$ is permitted to ensure correct measured values.



6.5 Alignment Display (Housing)

The sensor housing KEC-1 can be turned in both directions, max. 345 °. For this purpose, the housing-connecting nut must be opened. The housing can be rotated to the desired position, a bigger rotation angle is prevented by internal stop pins.

After that, the housing-connecting nut is firmly retighten

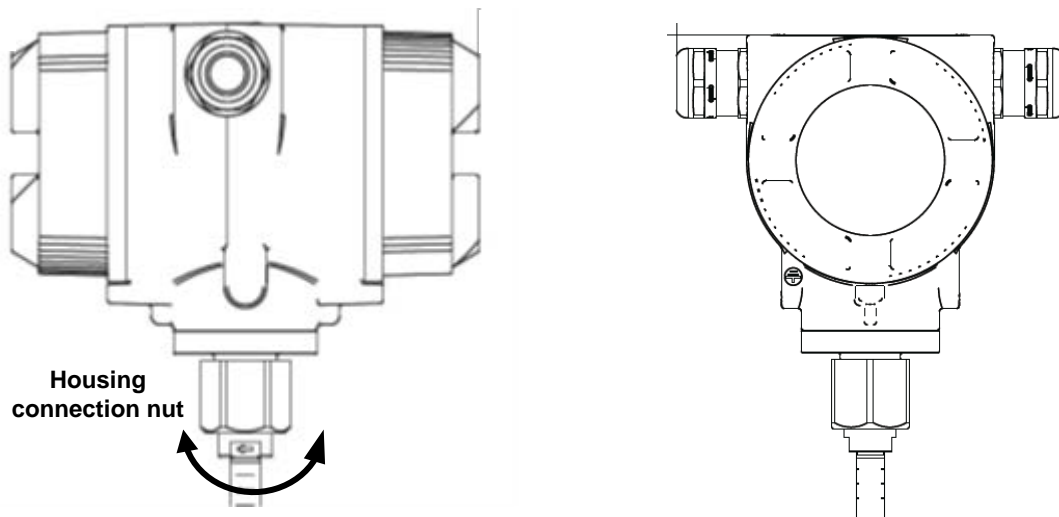

6.6 Tightening torques

To secure and guarantee of the function and tightness following tightening torques have to be applied, see table 1.

Table 1

Pos	Description	Tightening torque [Nm]
20	KEC-1 cover with glass	3
30	KEC-1 cover without window	3
50	Grub screw with hexagon socket M4x6 DIN 914 A2	2
130	KEC-1 nut	15
150	Cylinder screw DIN 6912 - M5x10 A2-70	4

7 Connection diagram

7.1 Cable glands - clamping ranges

For ensuring the tightness and strain relief, connector cables with the following diameters must be used.

KEC-1 Standard clamping range : Ø 5- 9mm

7.2 Connector pin assignment

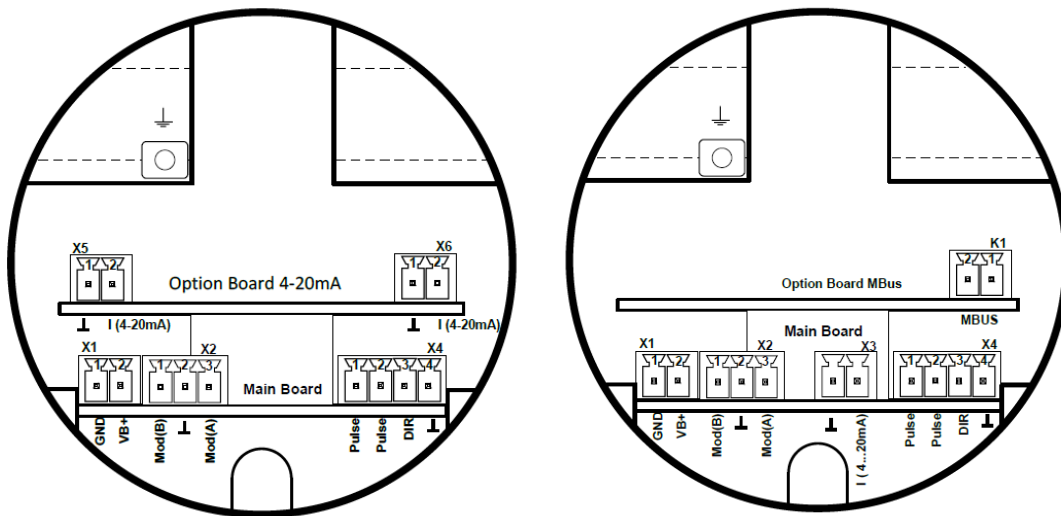

Connector	Pin	Signal description
X1 Power supply	1	VB - (GND)
	2	VB+ (12V – 36 Vdc)
X2 Modbus	1	Modbus (B)
	2	Modbus shield
	3	Modbus (A)
X3 Current output	1	I- Aktiv
	2	I+ Aktiv
X4 Direction / Pulset	1	Pulse / Alarm *
	2	Pulse / Alarm *
	3	Direction input
	4	GND
X5 Current output 1	1	I- Active**
	2	I+ Active **
X6 Current output 2	1	I- Active **
	2	I+ Active **
K1 MBus	1	MBus
	2	MBus

* Outputs are galvanically isolated.

** The Current outputs, X5 and X6, are optional. (Active and passive version available).

7.3 Wire connection

7.3.1 General:

- Wiring to be done in strainless state only.
- Length of cable skinning to be minimized
- Not used cable entries must be closed with end caps
- Use of cables with cross section of $\geq 0.25\text{mm}^2$

7.3.2 Power supply

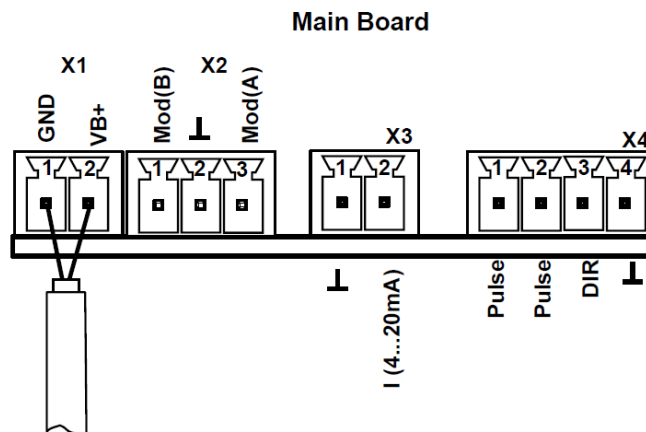

7.3.3 Modbus (termination):

If the sensor placed at the end of the Modbus system a termination is required. Therefore, the enclosed 120R resistor is to be connected at Pin 1 and Pin 3 of connector „X2“

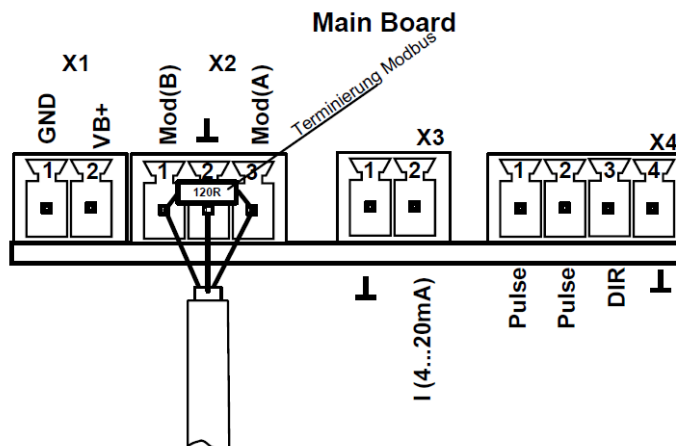

7.3.4 Pulse Output

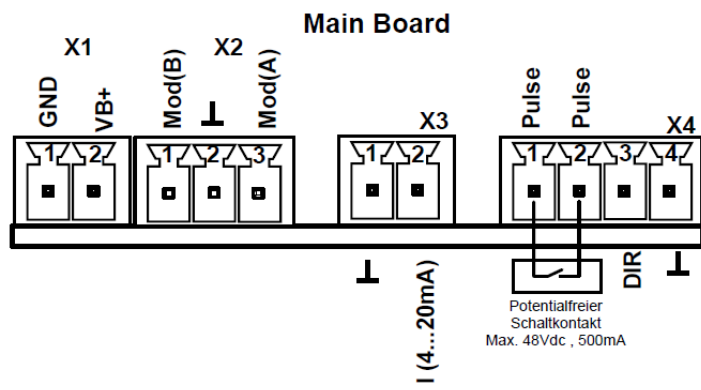

8 Operation KEC-1

The operation of the KEC-1 is carried out by 2 optical keys through the glass cover. Thus, the KEC-1 can be operated from the outside without opening the cap.

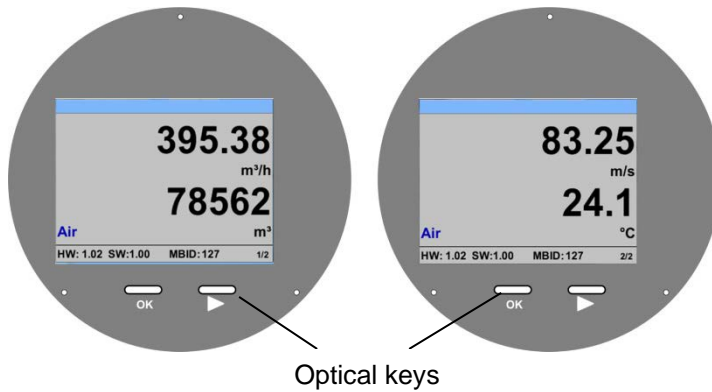

Selection of the individual menu items is done by pressing the ">" and confirm by pressing "OK".

Inputs or changes can be made with all white deposit fields, selected field will be highlighted with yellow background.

Words in **green font** refer mainly to the pictures in the section of the chapter, but also on important menu paths or menu items that are related to are in **green font**.

The menu navigation is generally in a **green font**!

The table of contents and chapter references in **blue font** contain links to the respective chapter title.

8.1 Main menu (Home)

8.1.1 Initialization

After switching on the KEC-1 the initialized screen is displayed followed by the main menu.

8.2 Main menu

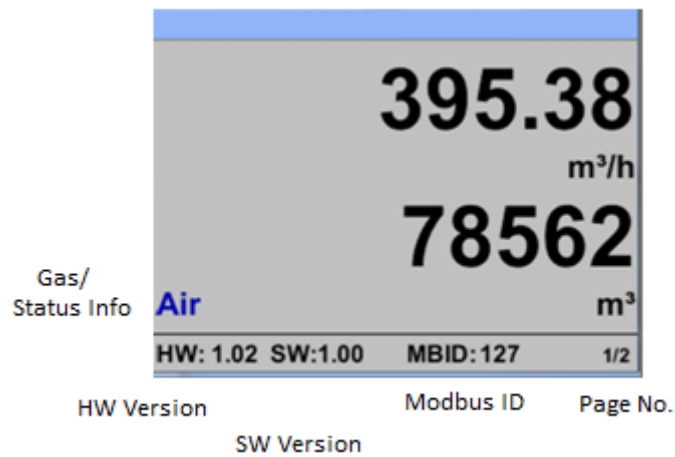

Switching to pages 2-4 or back by pressing key „△“

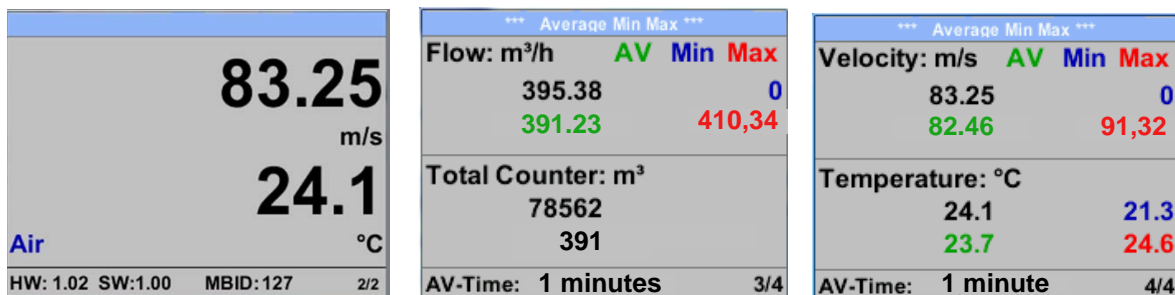

AV-Time (Period for average value calculation) could be changed under *Sensor Setup.-Advanced- AV-Time*

8.3 Settings

The settings menu could accessed by pressing the key „OK“.

But the access to the *settings menu* is password protected.



Factory settings for password at the time of delivery: 0000 (4 times zero).

If required the password could be changed at *Setup-User setup-Password*.

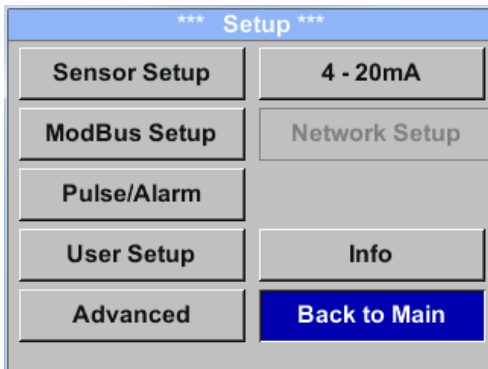

Selection of a menu item or to change a value is done with the key „ Δ “, a final move to the chosen menu item or takeover of the value change needs the confirmation by pressing the key „OK“

8.3.1 Sensor Setup

Setup → Sensor Setup

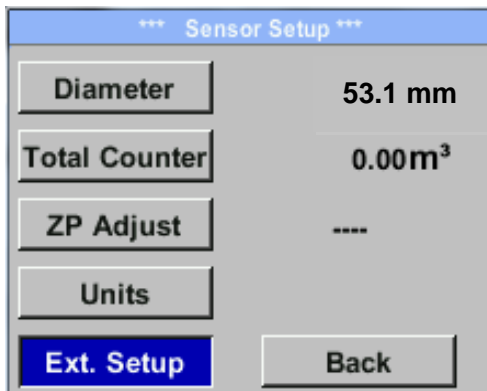

For changes, first select the menu item with key „Δ“ and then confirm it with **“OK”**.

8.3.1.1 Input / change tube diameter

Settings → Sensor Setup → Diameter

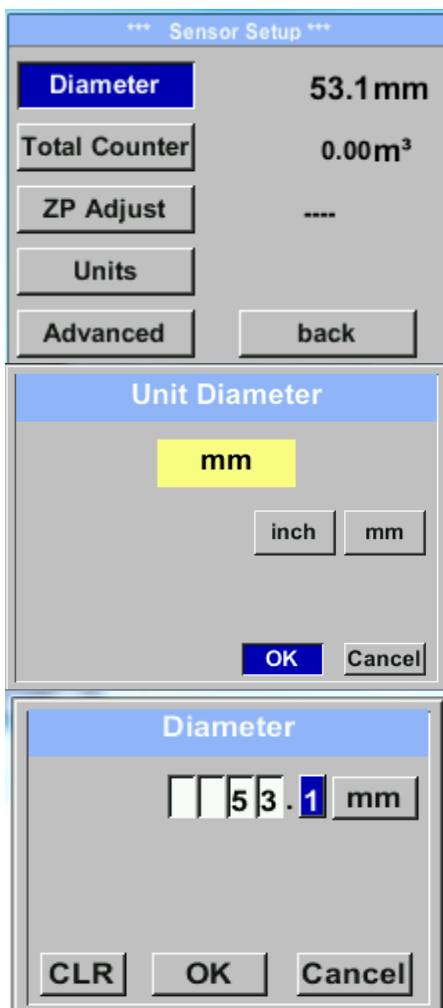

In order to change, e.g. the unit, first select by pressing key „Δ“ the field **“Units”** and then key **“OK”**.

Select with the key „Δ“ the correct unit and then confirm selection by pressing 2x **„OK”**.

Entering / changing the diameter via button „Δ“, select the respective position and activate the position with the **“OK”** button.

By pressing „Δ“ the position value is incremented by 1. Complete with **“OK”** and activate next number position. Confirm entry by pressing **„OK”**.

8.3.1.2 Input / change consumption counter

Setup → Sensor Setup → Total Counter → Unit button

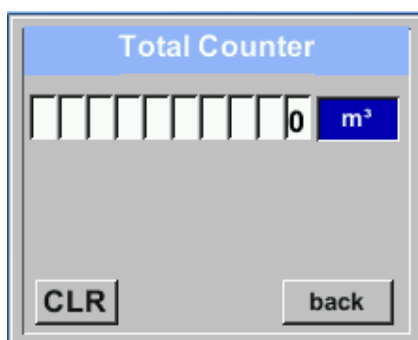
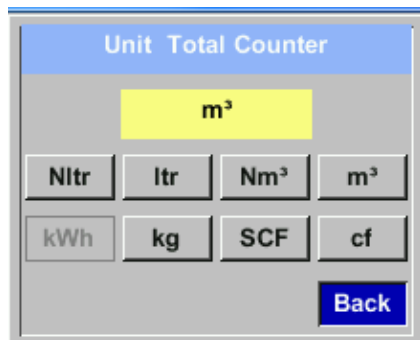

In order to change, e.g. the unit, first select by pressing key „△“ the button “Unit” and then key “OK”.

Select with the key „△“ the correct unit and then confirm selection by pressing 2x „OK”.

Entering / changing the consumption counter via button „△“, select the respective position and activate the position with the “OK” button.

By pressing „△“ the position value is incremented by 1. Complete with “OK” and activate next number position.

Confirm entry by pressing „OK”.

Important!

When the counter reach 10000000 m³ the counter will be reset to zero.

8.3.1.3 Definition of the units for flow, velocity, temperature and pressure

Setup → Sensor Setup → Units

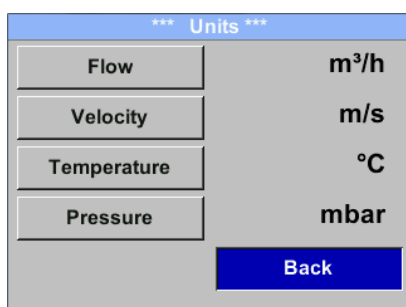

To make changes to the unit for the respective measurement value, first select by pressing „△“ the field of the „measurement value“ and activate „it with „OK”.

Selection of the new unit with „△“

In case the quantity of units selectable are not presentable on one page, pleas move to next page by pressing „<<“.

Confirm selection by pressing 2x „OK”.

Procedure for all 4 measurement-variables is analogous.

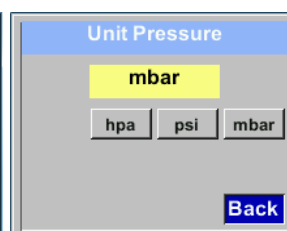
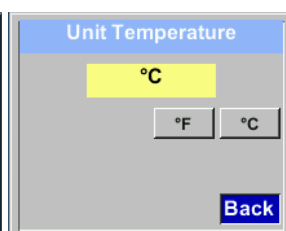
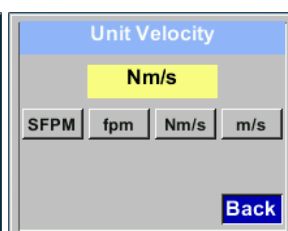
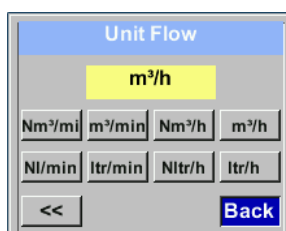

8.3.1.4 Definition of the reference conditions

Here can be defined the desired measured media reference conditions for pressure and temperature and times for the filter and averaging.

- Factory pre-setting for reference temperature and reference pressure are 20 °C, 1000 hPa
- All volume flow values (m³/h) and consumption values indicated in the display are related to 20 °C and 1000 hPa (according to ISO 1217 intake condition)
- Alternatively 0 °C and 1013 hPa (=standard cubic meter) can also be entered as a reference.
- **Do not enter the operation pressure or the operation temperature under reference conditions!**

Setup → Sensor Setup → Advanced

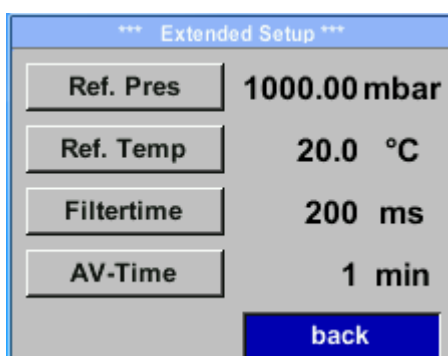

To make changes, first select a menu with button „△“ and confirm selection by pressing „OK“.

Setup → Sensor Setup → Advanced → Ref.Pref



In order to change, e.g. the unit, first select by pressing key „△“ the field “Units” and then key “OK”.

Select with the key „△“ the correct unit and then confirm selection by pressing 2x „OK”.

Input / change of the value by selecting the respective position with button „△“ and entering by pressing button „OK”.

Setup → Sensor Setup → Advanced → Ref.Temp

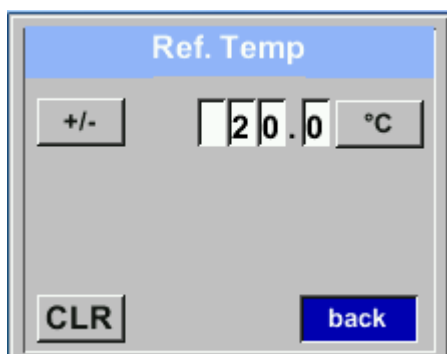

By pressing „△“ the position value is incremented by 1. Complete with “OK” and activate next number position.

Procedure for changing the reference temperature is the same.

Setup → Sensor Setup → Advanced → *Filtertime*

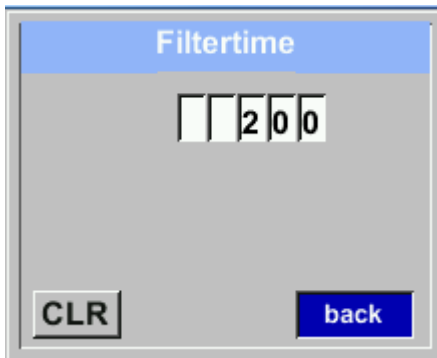

Under item "*Filtertime*" an attenuation can be defined.
Input values of 0 -10000 in [ms] are possible

Setup → Sensor Setup → Advanced → *AV-Time*

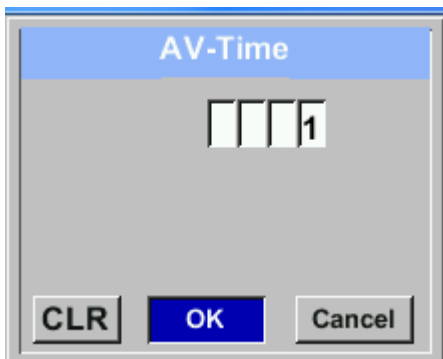

The time period for averaging can be entered here.
Input values of -1440 1 [minutes] are possible.
For average values see display window 3 + 4

8.3.1.5 Setting of Zeropoint and Low-flow cut off

Setup → Sensor Setup → ZP Adjust

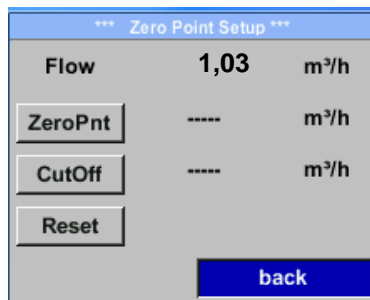

To make changes, first select a menu with button „ Δ “ and confirm selection by pressing „OK“.

Setup → Sensor Setup → ZP Adjust → ZeroPnt

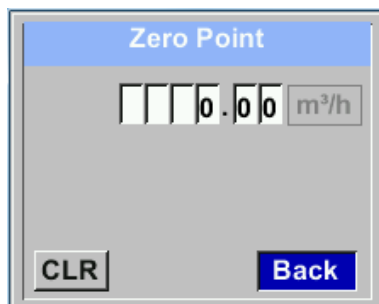

When, without flow, the installed sensor shows already a flow value of > 0 m³/h herewith the zero point of the characteristic could be reset.

For an input / change of the value select with the button „ Δ “ the respective number position and activate it with „OK“.

By pressing „ Δ “ the position value is incremented by 1. Confirm the input with „OK“ and activate next number position.

Leave menu with button „Back“

Setup → Sensor Setup → ZP Adjust → CutOff

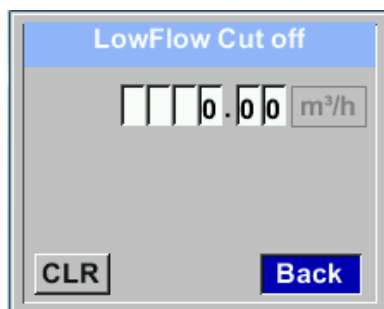

With the low-flow cut off activated, the flow below the defined "LowFlow Cut off" value will be displayed as 0 m³/h and not added to the consumption counter.

For an input / change of the value select with the button „ Δ “ the respective number position and activate it with „OK“.

By pressing „ Δ “ the position value is incremented by 1. Confirm the input with „OK“ and activate next number position.

Leave menu with button „Back“

Setup → Sensor Setup → ZP Adjust t → Reset

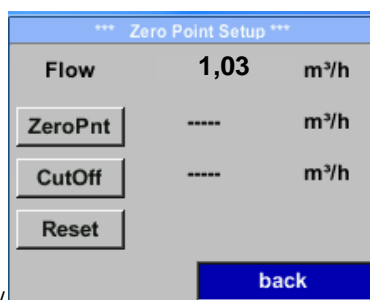

By selection of „Reset“ all settings for „ZeroPnt“ and „CutOff“ are reset.

Menu item to be select with button „ Δ “ and confirm the reset with „OK“.

Leave menu with button „Back“

8.3.2 Modbus Setup

The Flow sensors KEC-1 comes with a Modbus Interface.
Before commissioning the sensor, the communication parameters

- Modbus ID, Baudrate, Parity und Stop bit

must be set in order to ensure the communication with the Modbus master.

Settings → Modbus Setup

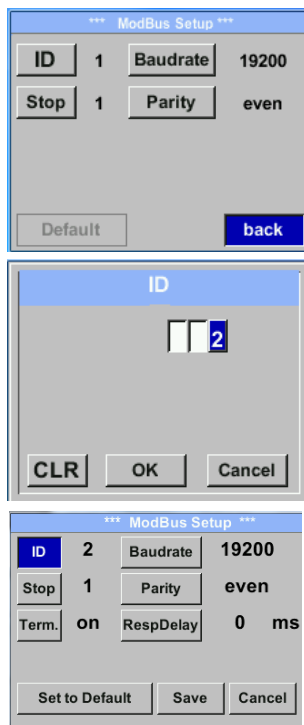

For changes, e.g. the sensor ID, first select by pressing key „ Δ “ the field “ID” and then key “OK”.

Select the desired position by pressing the “>” and select with “OK” button.

Change values by pressing the „ Δ “ values takeover by pressing “OK”.

Inputs for remaining information is analog.

Saving the changes by pressing “Save”, therefore select it first with key „ Δ “ and afterwards confirm it with “OK”.

To set back to default values please press button “Set to Default”

Default values out of factory:

Modbus ID:	1
Baud rate:	19200
Stopbit:	1
Parity:	even

Remark: If the sensor placed at the end of the Modbus system a termination is required.
Therefore, the enclosed 120R resistor is to be connected at Pin 1 and Pin 3 of connector „X2“

8.3.2.1 Modbus Settings (2001...2005)

Modbus Register	Register Address	No.of Byte	Data Type	Description	Default Setting	Read Write	Unit /Comment
2001	2000	2	UInt16	Modbus ID	1	R/W	Modbus ID 1...247
2002	2001	2	UInt16	Baudrate	4	R/W	0 = 1200 1 = 2400 2 = 4800 3 = 9600 4 = 19200 5 = 38400
2003	2002	2	UInt16	Parity	1	R/W	0 = none 1 = even 2 = odd
2004	2003	2	UInt16	Number of Stopbits		R/W	0 = 1 Stop Bit 1 = 2 Stop Bit
2005	2004	2	UInt16	Word Order	0xABCD	R/W	0xABCD = Big Endian 0xCDAB = Middle Endian

8.3.2.2 Values Register (1001 ...1500)

Modbus Register	Register Address	No.of Byte	Data Type	Description	Default	Read Write	Unit /Comment
1101	1100	4	Float	Flow in m ³ /h		R	
1109	1108	4	Float	Flow in Nm ³ /h		R	
1117	1116	4	Float	Flow in m ³ /min		R	
1125	1124	4	Float	Flow in Nm ³ /min		R	
1133	1132	4	Float	Flow in ltr/h		R	
1141	1140	4	Float	Flow in Nltr/h		R	
1149	1148	4	Float	Flow in ltr/min		R	
1157	1156	4	Float	Flow in Nltr/min		R	
1165	1164	4	Float	Flow in ltr/s		R	
1173	1172	4	Float	Flow in Nltr/s		R	
1181	1180	4	Float	Flow in cfm		R	
1189	1188	4	Float	Flow in Ncfm		R	
1197	1196	4	Float	Flow in kg/h		R	
1205	1204	4	Float	Flow in kg/min		R	
1213	1212	4	Float	Flow in kg/s		R	
1221	1220	4	Float	Flow in kW		R	

Operation

Modbus Register	Register Address	No. of Byte	Data Type	Description	Default	Read Write	Unit /Comment
1269	1268	4	UInt32	Consumption m ³ before comma	x	R	
1275	1274	4	UInt32	Consumption Nm ³ before comma	x	R	
1281	1280	4	UInt32	Consumption ltr before comma	x	R	
1287	1286	4	UInt32	Consumption Nltr before comma	x	R	
1293	1292	4	UInt32	Consumption cf before comma	x	R	
1299	1298	4	UInt32	Consumption Ncf before comma	x	R	
1305	1304	4	UInt32	Consumption kg before comma	x	R	
1311	1310	4	UInt32	Consumption kWh before comma	x	R	
1347	1346	4	Float	Velocity m/s			
1355	1354	4	Float	Velocity Nm/s			
1363	1362	4	Float	Velocity Ft/min			
1371	1370	4	Float	Velocity NFt/min			
1419	1418	4	Float	GasTemp °C			
1427	1426	4	Float	GasTemp °F			

Remark:

- For more additional Modbus values please refer to
KECXX_Modbus_RTU_Slave_Installation_1.00_EN.doc

8.3.3 Pulse /Alarm

Setup → Sensor Setup → Pulse/ Alarm

Relay Mode:	Alarm
Unit	°C
Value	20.0
Hyst.	5.0
Hi-Lim.	OK Cancel

*** Pulse / Alarm ***	
Relay Mode:	Alarm
Unit:	°C
Value	20.0
Hyst.	5.0
Hi-Lim.	OK Cancel

*** Pulse / Alarm ***	
Relay Mode:	Pulse
Unit:	m³
Value	0.1
Polarity	pos.
Pls per second at max Speed: 0	
Back	

The galvanically isolated output can be defined as pulse- or alarm output. Selection of field „**Relay Mode**“ with key „**Δ**“ and change modus by pressing key „**OK**“.

For alarm output following units could be chosen: kg/min, cfm, ltr/s, m³/h, m/s, °F, °C and kg/s.

„**Value**“ defines the Alarm value, „**Hyst.**“ defines the desired hysteresis and with „**Hi-Lim**“ or „**Lo-Lim**“ the alarm settings when the alarm is activated
 Hi-Lim: Value over limit
 Lo-Lim: Value under limit

For the pulse output following units could be chosen: kg, cf, ltr and m³. The pulse value definition to be done in menu „**Value**“ (0.1, 1, 10, 100). With „**Polarity**“ the switching state could be defined.
 Pos. = 0 → 1 neg. 1 → 0

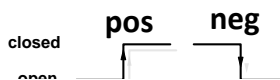

8.3.3.1 Pulse output

The maximum frequency for pulse output is 50 pulses per second (50Hz). The Pulse output is delayed by 1 second.

Pulse value	[m³ /h]	[m³ /min]	[l/min]
0.1 ltr / Pulse	1,8	0,3	300
1ltr / Pulse	18	3	3000
0.1m³ / Pulse	18000	300	300000
1 m³ / Pulse	180000	3000	3000000

Table 1 Maximum flow for pulse output

Entering pulse values that are not allow a presentation to the full scale value, are not allowed. Entries are discarded and error message displayed.

8.3.4 User Setup

Settings → UserSetup

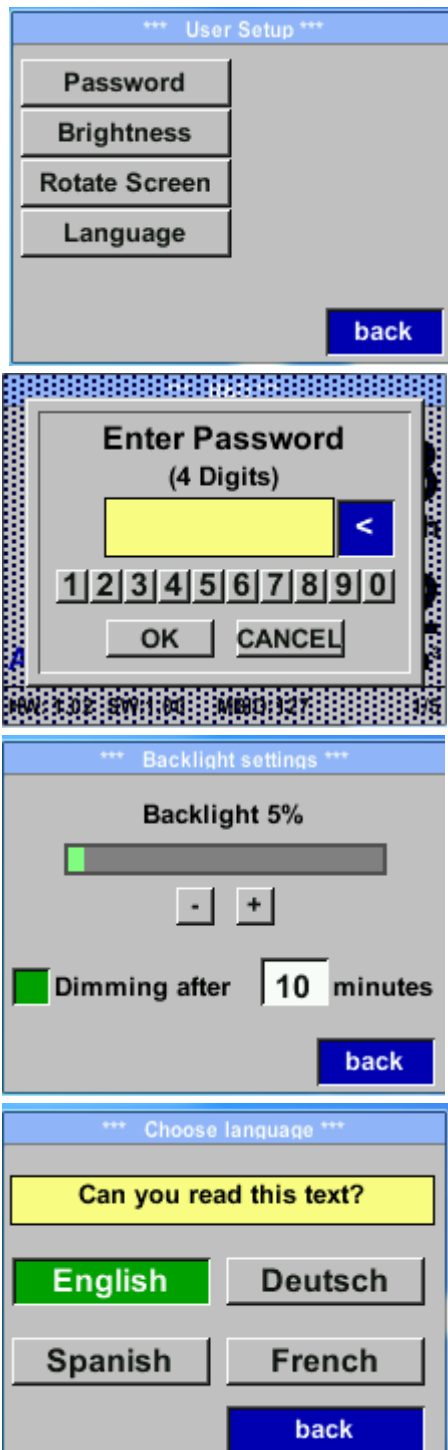

To make changes, first select a menu with button „ Δ “ and confirm selection by pressing „OK“.

It is possible to define a password. The required password length is 4 digits.

Please select with button „ Δ “ a figure and confirm it with „OK“. Repeat this 4 times.

With „ \leftarrow “ the last figure could be deleted.

Password input have to be inserted twice.

Confirmation of input/password by pressing „OK“.

Factory settings for password at the time of delivery: 0000 (4 times zero).

With „*Brightness*“ it is possible to adjust the backlight / display brightness.

By activation “*Dimming after*” and entering a time a display dimming could be set.

With „*Rotate Screen*“ the display information could be rotated by 180°.

Currently 4 languages have been implemented and could be selected with button „ Δ “.

Change of language by confirming with “OK”. Leaving the menu with button “back”.

8.3.5 Advanced

Settings → *Advanced*

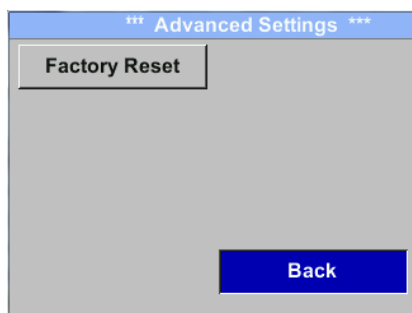

By pressing „*Factory Reset*“ the sensor is set back to the factory settings.

8.3.6 4 -20mA

Settings → 4-20mA

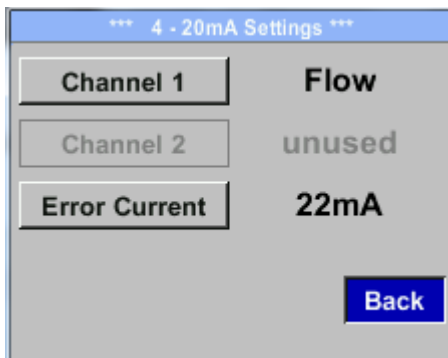

To make changes, first select a menu with button „ Δ “ and confirm selection by pressing „OK“.

Settings → 4-20mA → Channel 1

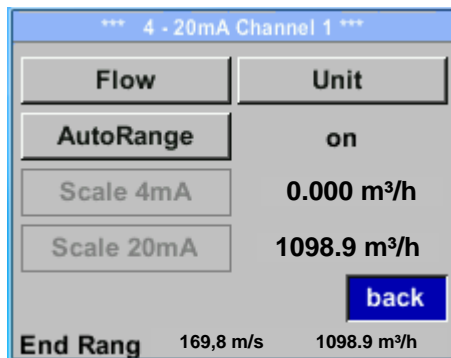

The 4-20 mA Analogue output of the Sensor KEC can be individually adjusted.

It is possible to assign following values „Temperature“, „Velocity“ und „Flow“ to the channel CH 1.

To make changes, first select the value item with button „ Δ “ .and confirm
Moving between the different measurements values or to deactivate the 4-20mA with setting to „unused“ by pressing „OK“.

To the selected measurement value a corresponding / appropriate unit needs to be defined. Select „Unit“ with „ Δ “ and open menu with „OK“.
Select required unit with „ Δ “ and take over by pressing „OK“.

Here e.g. for the measurement value Flow, procedure for the other measurements values is analog.

For saving the changes done press button „Save“ to discard the changes press button „Cancel“.

Leaving the menu with „Back“.

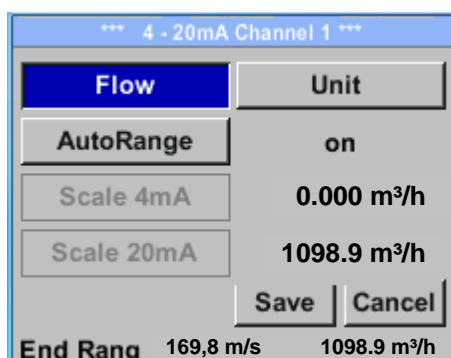
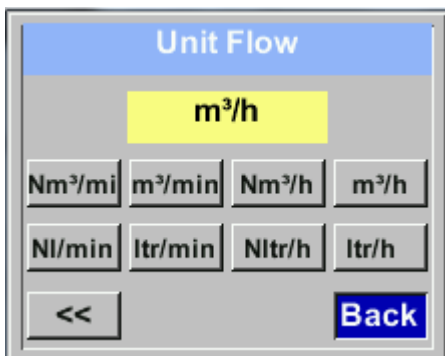

Settings → 4-20mA → Channel 1 → AutoRange

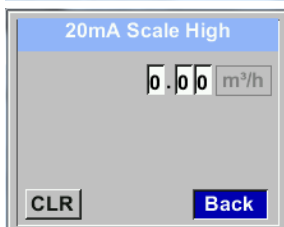
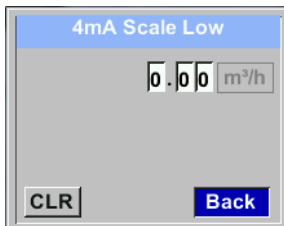
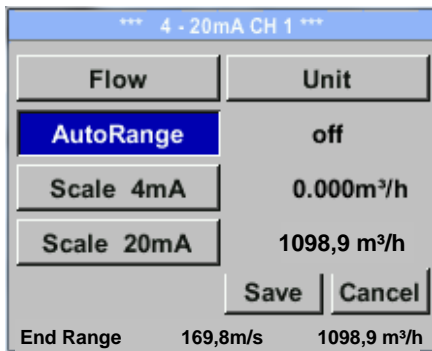

The scaling of the 4-20mA channel can be done automatically "Auto Range = on" or manual "AutoRange = off" .

With button „ Δ “ select the menu item „AutoRange“ select with „OK“ the desired scaling method. (Automatically or manually)

In case of **AutoRange = off** with „Scale 4mA“ and „Scale 20mA“ the scale ranges needs to be defined.

Select with button „ Δ “ the item „Scale 4mA“ or „Scale 20mA“ and confirm with „OK“ .

Input of the scaling values will be analogous as described before for value settings.

Using „CLR“ clears up the complete settings at once.

For „Auto on“, the max. scaling is calculated based on the inner tube diameter, max. measurement range and the reference conditions settings.

Take over of the inputs with „Save“ and leaving the menu with „Back“.

Settings → 4-20mA → Error Current

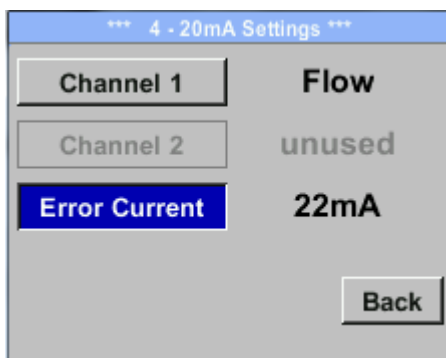

This determines what is output in case of an error at the analog output.

- 2 mA Sensor error / System error
- 22 mA Sensor error / System error
- None Output according Namur (3.8mA – 20.5 mA)
 < 4mA to 3.8 mA Measuring range under range
 >20mA to 20.5 mA Measuring range exceeding

To make changes first select a menu item "Current Error" with button „ Δ “ and then select by pressing the „OK“ the desired mode

For saving the changes done press button „Save“ to discard the changes press button „Cancel“.

Leaving the menu with „Back“.

8.3.7 KEC-1 Info

Setup → Sensor Setup → Info

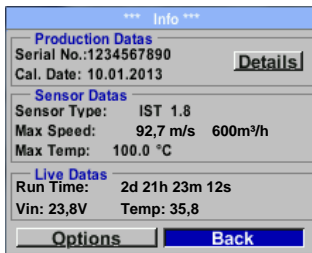

Here you get a brief description of the sensor data incl. the calibration data.

Under **Details**, you are able to see in addition the calibration conditions.

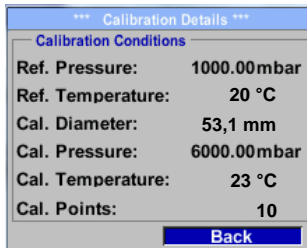

8.4 MBus

8.4.1 Default Settings communication

Primary Adress*: 1
 ID: Serialnumber of Sensor
 Baud rate*: 2400
 Medium*: depending on medium (Gas or Compressed Air)

Both addresses, Primary address and ID, could be automatic searched in the M-Bus system.

8.4.2 Default values transmitted

Value 1 with [Unit]*: Consumption [m³]
 Value 2 with [Unit]*: Flow [m³/h]
 Value 3 with [Unit]*: Gas temperature [°C]

*All Values could be changed / preset in production or with Kobold Service software

9 EU Declaration of Conformance

Wir, Kobold Messring GmbH, Hofheim-Ts., Bundesrepublik-Deutschland, erklären, dass das Produkt

Thermal Energy Flowmeter for gases

Model: KEC-1

to which this declaration relates is in conformity with the standards noted below:

EN 55011:2016 + A1:2017 Industrial, scientific and medical equipment - Radio-frequency disturbance characteristics - Limits and methods of measurement

EN 61326-1:2013 Electrical equipment for measurement, control and laboratory use - EMC requirements - Part 1: General requirements

Also, the following EU guidelines are fulfilled:

2014/30/EU

EMC Directive

2011/65/EU

RoHS

2015/863/EU

Delegated Directive (RoHS III)

Hofheim, 14 Oct. 2021



H. Volz
General Manager



M. Wenzel
Proxy Holder