

Operating Instructions
for
Compact Magnetic-Inductive
Flow Meter

Model: MIK



1. Contents

1. Contents.....	2
2. Note	3
3. Instrument Inspection.....	3
4. Regulation Use	4
5. Operating Principle.....	5
5.1 General.....	5
5.2 Minimum electrical conductivity / contained gases	5
5.3 Deposits.....	6
5.4 Measuring electrodes	6
6. Mechanical Connection.....	7
6.1 Check operating conditions.....	7
6.2 Installation.....	7
7. Electrical Connection	9
7.1 General.....	9
7.2 MIK-...S300.....	9
7.3 MIK-...S30D	9
7.4 MIK-...F300; MIK-...L3x3.....	10
7.5 MIK-...L443	10
7.6 MIK-...C30.....	10
7.7 MIK-...C34.....	10
7.8 MIK-...Ex4R, MIK-...Gx4R.....	11
8. Operation	12
8.1 Switch point setting MIK-...S300, MIK-...S30D	12
8.2 Counter electronics MIK-...Ex4R.....	12
8.3 Dosing electronics MIK-...Gx4R	12
9. Adjustments – Compact Electronics MIK-...C3.....	13
9.1 Button function.....	13
9.2 Settings.....	13
9.3 Value setting	14
9.4 Set-up mode	15
9.5 Main menu items	17
10. Maintenance	21
11. Technical Information.....	22
12. Order Codes	25
13. Dimensions	26
14. Disposal	29
15. EU Declaration of Conformance	30
16. UK Declaration of Conformity.....	31

Manufactured and sold by:

Kobold Messring GmbH
Nordring 22-24
D-65719 Hofheim
Tel.: +49(0)6192-2990
Fax: +49(0)6192-23398
E-Mail: info.de@kobold.com
Internet: www.kobold.com

2. Note

Please read these operating instructions before unpacking and putting the unit into operation. Follow the instructions precisely as described herein.

The instruction manuals on our website www.kobold.com are always for currently manufactured version of our products. Due to technical changes, the instruction manuals available online may not always correspond to the product version you have purchased. If you need an instruction manual that corresponds to the purchased product version, you can request it from us free of charge by email (info.de@kobold.com) in PDF format, specifying the relevant invoice number and serial number. If you wish, the operating instructions can also be sent to you by post in paper form against an applicable postage fee.

The devices are only to be used, maintained and serviced by persons familiar with these operating instructions and in accordance with local regulations applying to Health & Safety and prevention of accidents.

When used in machines, the measuring unit should be used only when the machines fulfil the EC-machine guidelines.

as per PED 2014/68/EU

In acc. with Article 4 Paragraph (3), "Sound Engineering Practice", of the PED 2014/68/EU no CE mark.

Diagram 8, Pipelines, Group 1, dangerous fluids

3. Instrument Inspection

Instruments are inspected before shipping and sent out in perfect condition.

Should damage to a device be visible, we recommend a thorough inspection of the delivery packaging. In case of damage, please inform your parcel service / forwarding agent immediately, since they are responsible for damages during transit.

Scope of delivery:

The standard delivery includes:

- Compact Magnetic-Inductive Flow Meter model: MIK

4. Regulation Use

Any use of the Compact Magnetic-Inductive Flow Meter, model: MIK, which exceeds the manufacturer's specifications, may invalidate its warranty. Therefore, any resulting damage is not the responsibility of the manufacturer. The user assumes all risk for such usage.

5. Operating Principle

5.1 General

The new KOBOLD flow meter Type MIK is used for measuring and monitoring smaller and medium-sized flow of conductivity liquids in pipes. The device operates according to the electromagnetic measuring method. According to Faraday's Law of electromagnetic induction a voltage is induced in a conductor moving through a magnetic field. The electroconductive measuring medium acts as the moved conductor. The voltage induced in the measuring medium is proportional to the flow velocity and is therefore a value for the volumetric flow. The flowing media must have a minimum conductivity. The induced voltage is picked up by two sensing electrodes which are in contact with the measuring medium and sent to the measuring amplifier. The flow rate will be calculated based on the cross-sectional area of the pipe.

The measurement is not depending on the process liquid and its material properties such as density, viscosity and temperature.

The device may be equipped with a switch, frequency or analogue output. Moreover, there is a compact electronic system to be selected from, which contains a digital display, a switch and an analogue output.

The device series is completed by an optionally obtainable dosing and counter electronic system. The counter electronic system shows the current flow rate on the first line of the display and shows the partial or overall volume on the second line. A dosing electronic system controls simple filling duty and also measures the flow rate, overall volume and filling volume. The analogue output and two relay outputs can be utilised for the further processing of signals.

5.2 Minimum electrical conductivity / contained gases

It is necessary for the correct function of the device that the current canal is always filled completely with medium.

As of a minimum electrical conductivity of 30 $\mu\text{S}/\text{cm}$ the MIK works within the guaranteed margins of error. The conductivity of the medium is continuously monitored by the device's electronic system. If the electronic system registers that the conductivity has under-run minimum, the output signal is suppressed for 2 seconds, after which the value for zero flow is output.

Air bubbles in the flowing medium or media with changing conductivity in the range of the minimum conductivity can interfere with the measuring function and reduce the MIK's measuring accuracy.

The gases contained in the fluid are included in the volume flow measurements and consequently cause erroneous measurements. If necessary, suitable vents should be fitted upstream in the device.

5.3 Deposits

Minor deposits on the measuring tube do not compromise the accuracy of measurement in general, as long as their conductivity does not seriously deviate from that of the fluid. In the case of fluids that have a tendency to deposit sediment, the measuring tube should be checked at regular intervals and cleaned if necessary.

5.4 Measuring electrodes

The electrodes used with the MIK have a galvanic pick-off. They are in direct contact with the fluid and are fitted opposite one another, and insulated from the measuring tube. The standard electrodes are made of 1.4404 stainless steel or Hastelloy C4.

6. Mechanical Connection

6.1 Check operating conditions

- flow rate
- max. operating pressure
- max. operating temperature

In general, the MIK is subjected to the same loads as the piping into which it is installed. The MIK should therefore be kept away from extreme loads, such as pressure surges with strong, dynamic pipe movements, vibrations in the proximity of centrifugal pumps, high temperature media, flooding etc.

6.2 Installation

- Remove all packing materials and transport retainers and ensure that no such materials remain in the device.
- It can be installed in vertical, horizontal or rising pipes. Flow in direction of the arrow.
- Avoid pressure and tensile load.
- Mounting the inlet and outlet pipe in a distance of 50 mm from the connections.



Attention! The sensor housing made of PPS and PVDF is not allowed to be subjected to a torsional stress during installation. The connecting of the respective connection thread with the pipeline should be adapted to the material used, over tightening the connection will damage the sensor housing, a loose tightening may result in loosening the connection.

- Avoid valves or large reduction on the inlet section (this increases the inaccuracy of measurements).
- Check the leak tightness of the connections.

in- and outlet

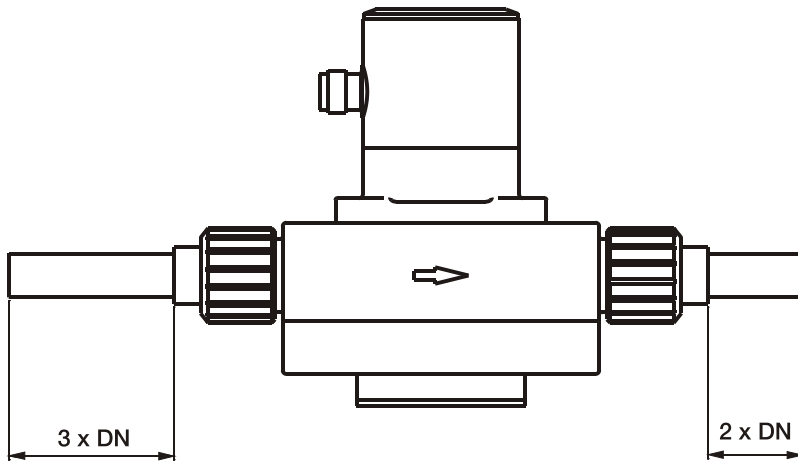

mounting top down

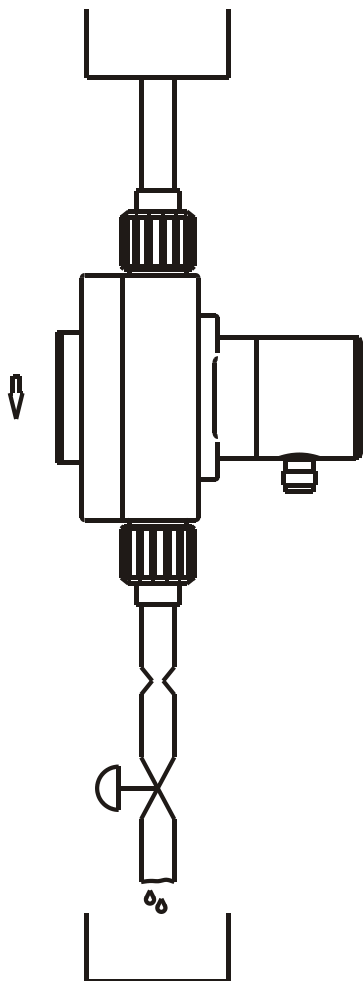

avoid this mounting position

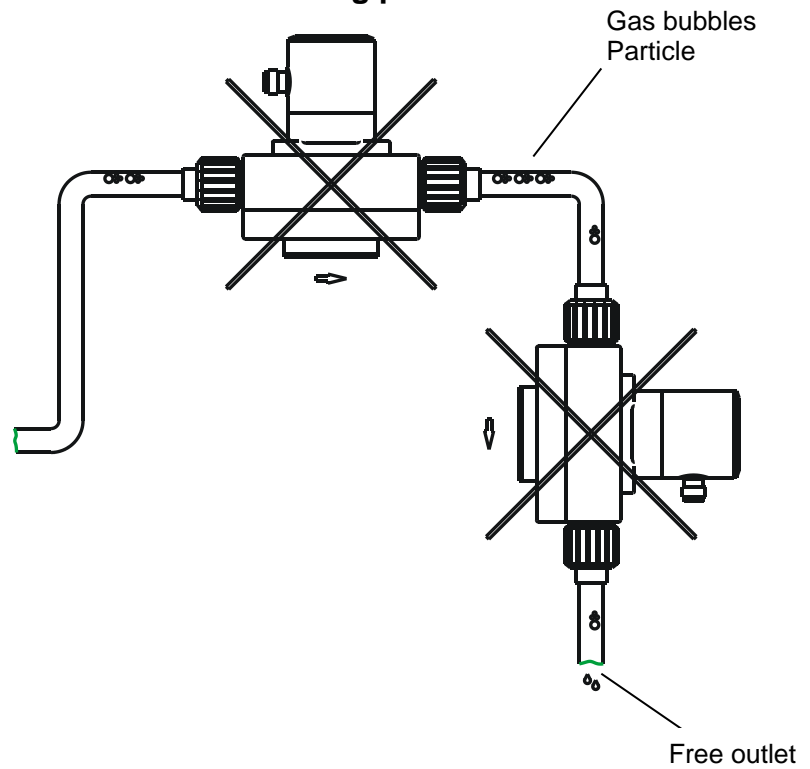

7. Electrical Connection

7.1 General



Attention! Make sure that the voltage values of your system correspond with the voltage values of the measuring unit.

- Make sure that the supply wires are de-energised.
- Connect the supply voltage and the output signal **to the plug PIN's as stated below.**
- We recommend the use of wires with cross sectional area of min. 0,25 mm².



Attention! The measuring electrodes are galvanically connected with the reference potential of the supply voltage and the signal output.

7.2 MIK-...S300

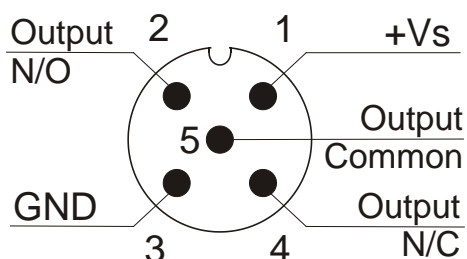

7.3 MIK-...S30D

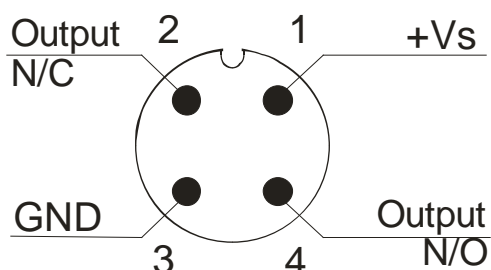

7.4 MIK-...F300; MIK-...L3x3

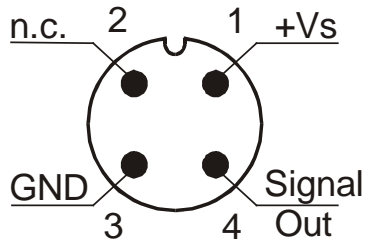

Connection example MIK-...L3x3

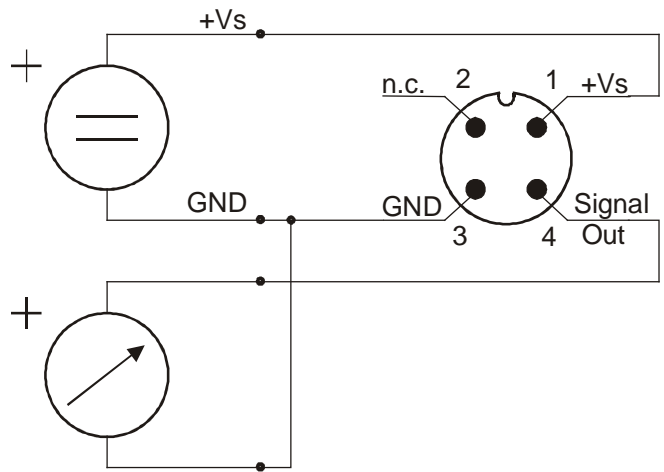

7.5 MIK-...L443

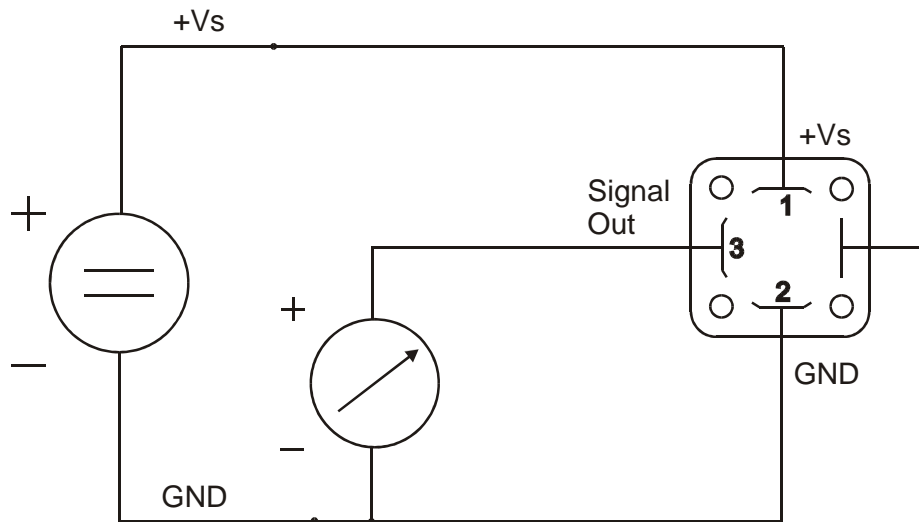

7.6 MIK-...C30..

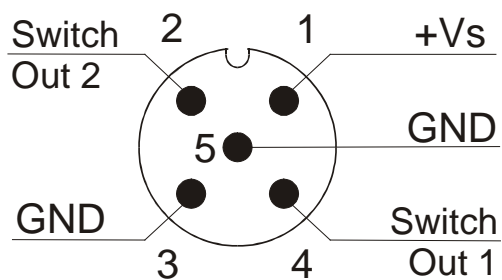

7.7 MIK-...C34..

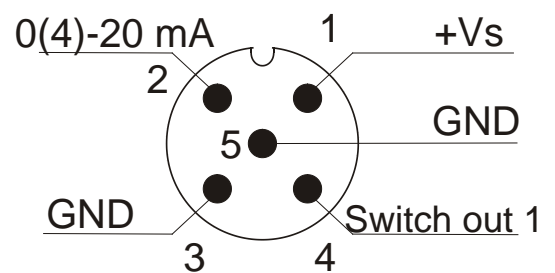

7.8 MIK-...Ex4R, MIK-...Gx4R

Cable connection

Wire number	MIK-...E14R Counter electronics	MIK-...G14R Dosing electronics
1	+24 V _{DC}	+24 V _{DC}
2	GND	GND
3	4-20 mA	4-20 mA
4	GND	GND
5	n. c.	Control 1*
6	Reset part quantity	Control 2*
7	Relay S1	Relay S1
8	Relay S1	Relay S1
9	Relay S2	Relay S2
10	Relay S2	Relay S2

*Control 1<->GND: Start-dosing
 Control 2<->GND: Stop-dosing
 Control 1 <-> Control 2 <-> GND: Reset-dosing

Plug connection

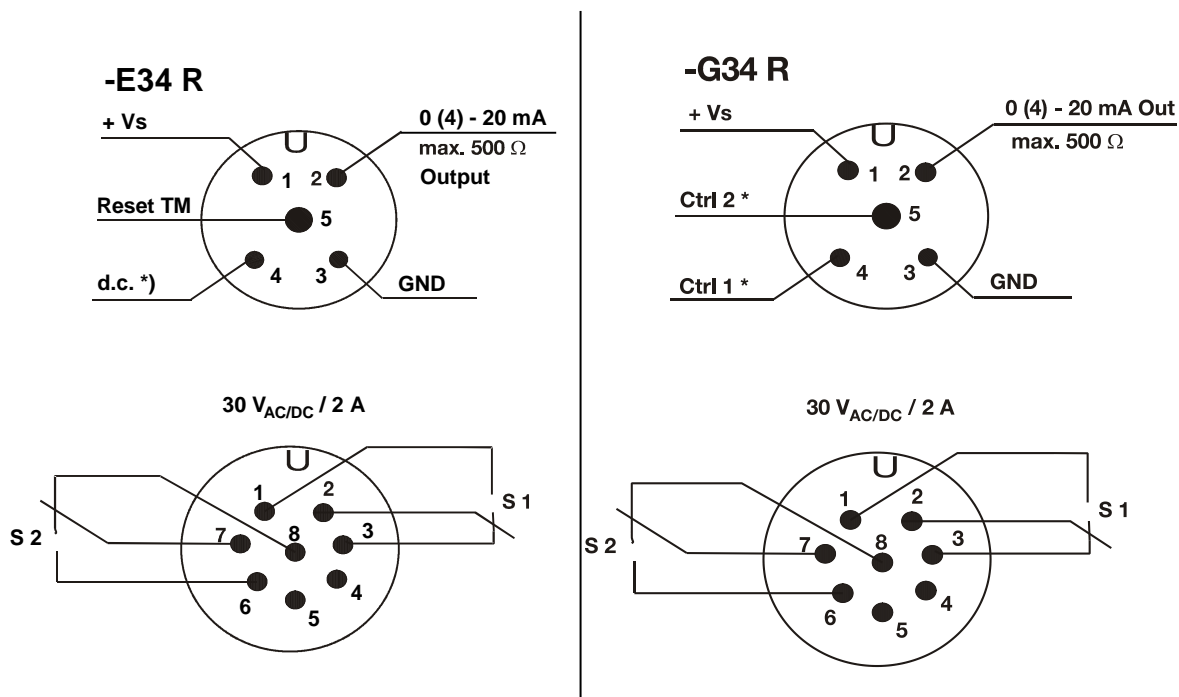

*) Do not connect!

8. Operation

The units are preset and after electrical connection ready for operation.

8.1 Switch point setting MIK-...S300, MIK-...S30D

Switch setting	Switch point
0	Switch function deactivated
1	10 % of f.s.
2	20 % of f.s.
3	30 % of f.s.
4	40 % of f.s.
5	50 % of f.s.
6	60 % of f.s.
7	70 % of f.s.
8	80 % of f.s.
9	90 % of f.s.

Flow above switch point: DUO-LED green
Flow below switch point: DUO-LED red

8.2 Counter electronics MIK-...Ex4R

Operating please see Operating Instructions ZED-Z

8.3 Dosing electronics MIK-...Gx4R

Operating please see Operating Instructions ZED-D

9. Adjustments – Compact Electronics MIK-...C3..

Connect the compact electronics according to previous connection diagram and supply with the indicated power supply.

After power on, the measuring range (end current) will be shown for 3 seconds.

9.1 Button function

In the standard mode (measuring mode)

 : Press 3 sec. → Setup mode

 : Switch point/Window point

In the set-up mode

 : Next Step

 : Change Value

Any time

3 sec 

or do not press
a button for 20 sec

↓

Standard mode

9.2 Settings

The following values can be changed in the compact electronic:

	Scale range	Factory setting
Switch point (SPo , SP1 , SP2)	0...999	0,00
Hysteresis (HYS)	-199...0	-0,00
Window point (duo point) (duo)	Switch point ...999	--- (inactive)
Contact-type (Con , Co1 , Co2)	(no),(nc) or frequency (Fr)**	no
Start current (S-C)*	000...999	000
End current (E-C)*	000...999	FS
Start current selection (SCS)	0-- (0 mA), 4-- (4 mA)	4 mA
Change Code (CCo)	000...999	000

* Start- and end value of flow relating to 0/4-20 mA

** **not calibrated**, frequency at f.s. approx. 1100-1600 Hz

9.3 Value setting

From the main menu item (for example: switch point, "SPo"), press the "◆" button to set the value. The flow chart below illustrates the universal routine for changing individual parameters.

[From the main menu item]

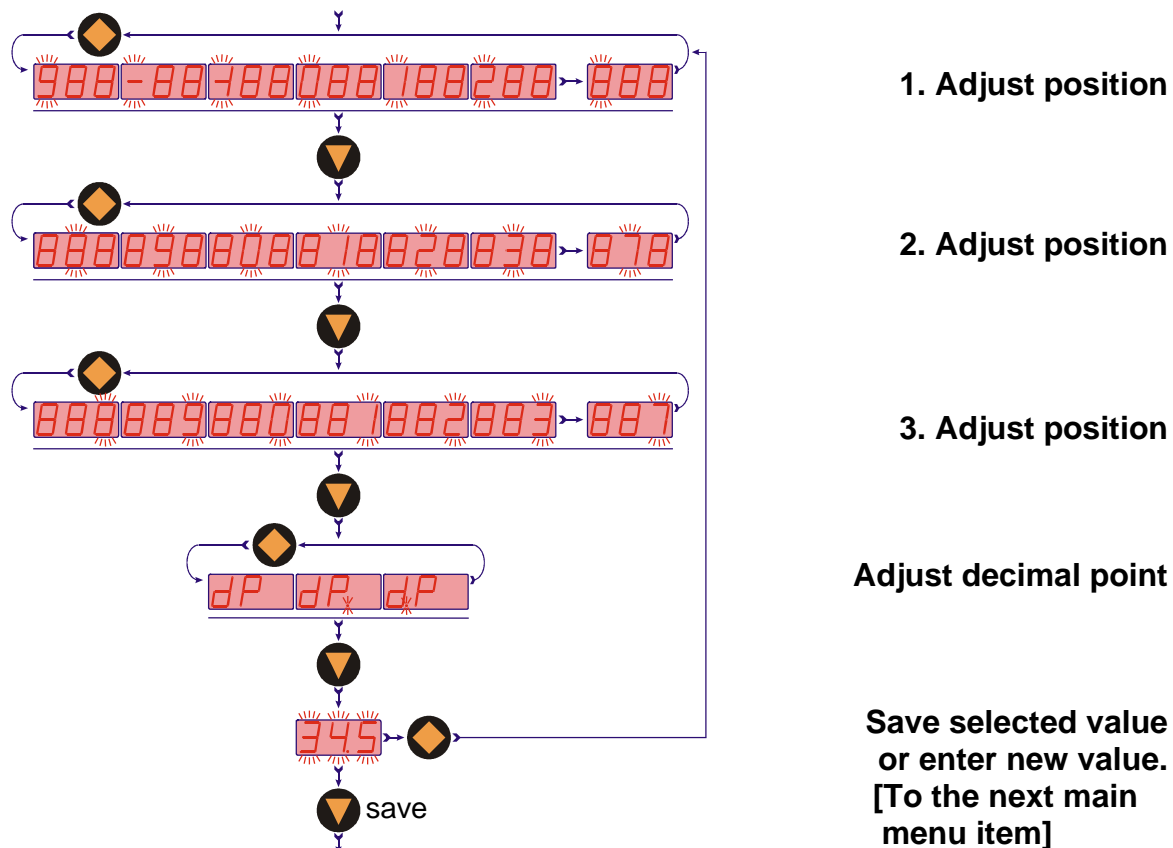

9.4 Set-up mode

Compact electronics MIK-...C30..

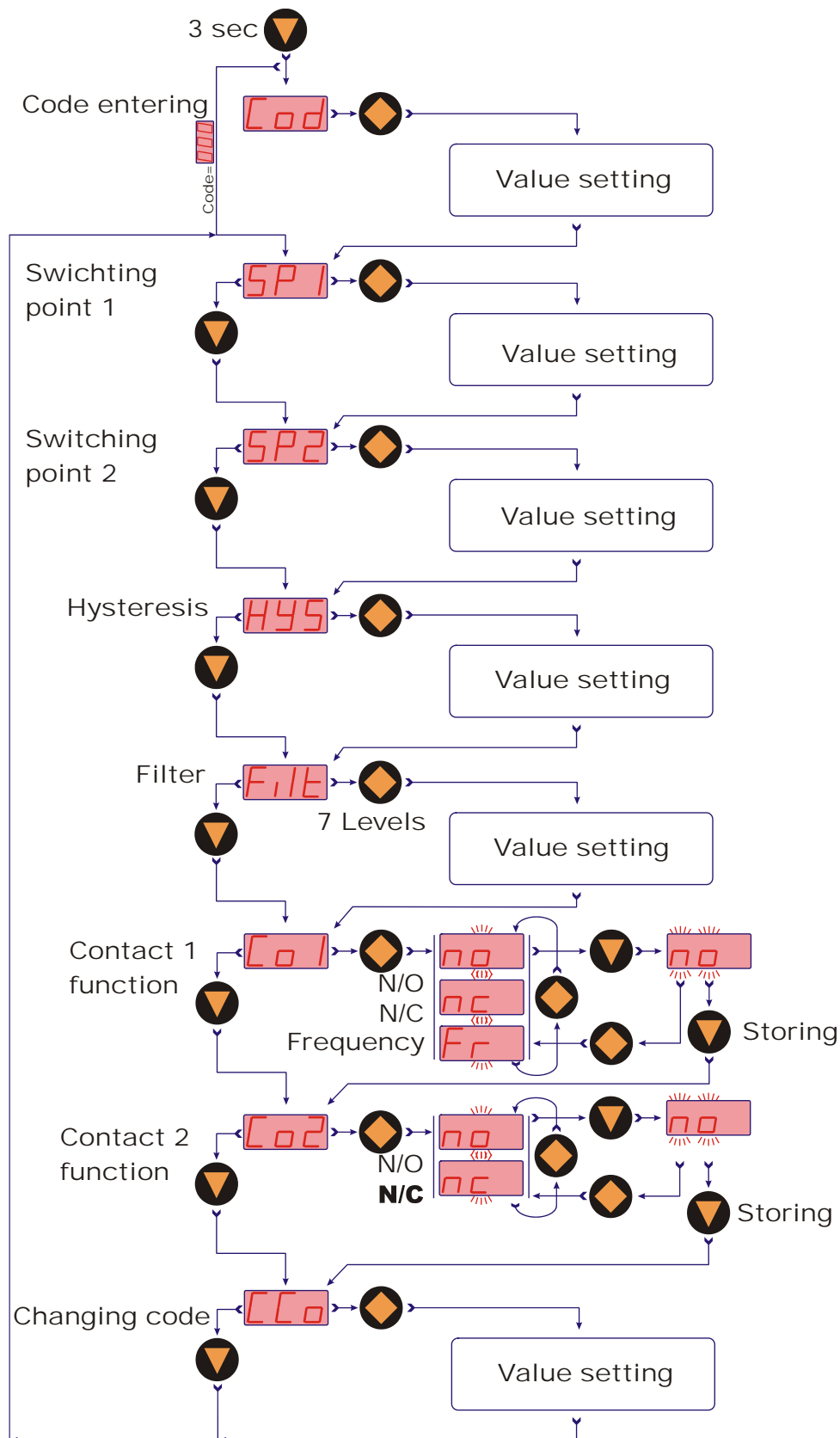

Compact electronics MIK-...C34..

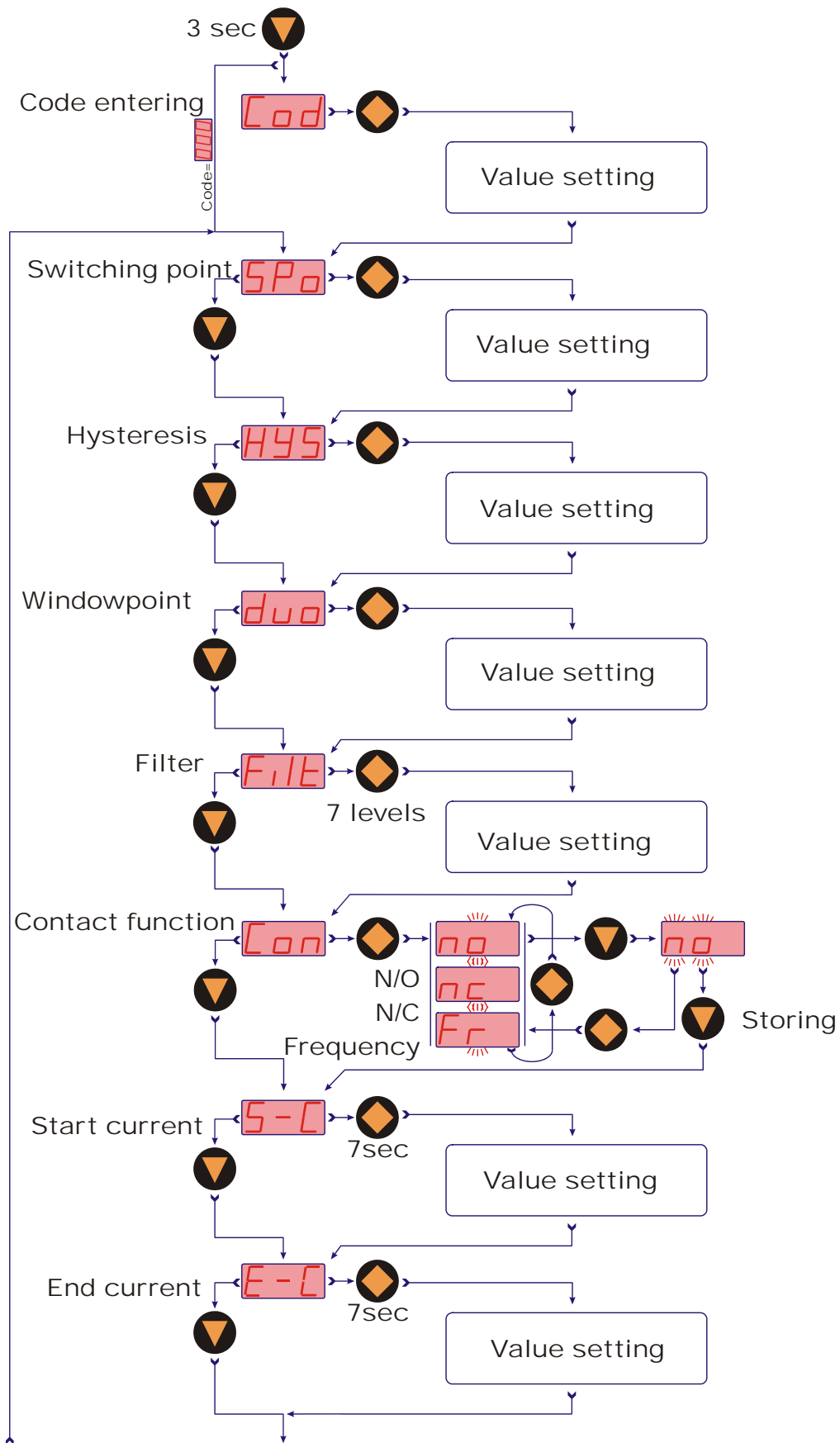

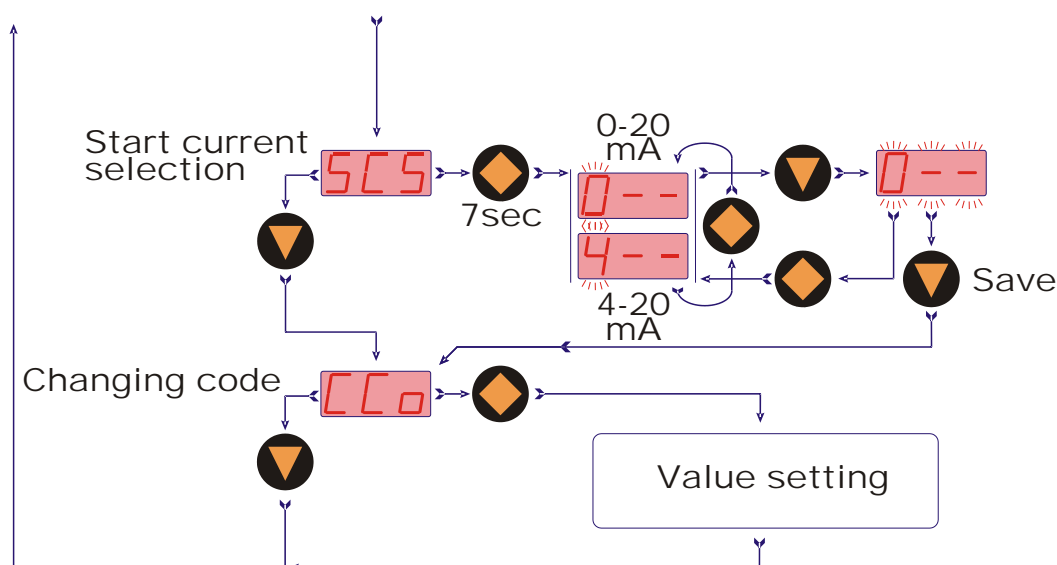

9.5 Main menu items

9.5.1 Switching point

The switching point is entered in the menu item "**Spo, SP1, SP2**". A setting value between 000 and 999 can be selected. This value can also include a decimal point. The decimal point can be set at two points (e.g. 10.0 or 1.00). If the display value exceeds the set switch point, the electronic is activated and is signalled by a lightning LED.

If the hysteresis is equal to zero and the window point is de-activated, the electronic switches back whenever the indicated value falls below the switching point.

9.5.2 Hysteresis

After the setting of the switching point, the hysteresis can be entered as a negative value in the "**HYS**" menu. The standard hysteresis value is zero. In operation condition this can lead to ambiguous switching behaviour, if the reading fluctuates around the switching point or window point. In this case, increasing the hysteresis can put things right. The hysteresis relates to the switching point and the window point (switching point minus hysteresis; window point plus hysteresis).

Example: Switch point 100 L/min; Hysteresis: -2.5 L/min

The electronics switches when 100 L/min is exceeded and switches back when the reading under-runs below 97.5 L/min.

9.5.3 Window point (duo-point)

As well as the switching point, it is also to define a "duo" (duo-point), the window point. This must be higher than the switching point. By using the window point and the switching point it is possible to monitor the measurement value in a certain range. The switching point limits the measurement range to smaller values and the window point to larger values.



If the window point (duo-point) is less than or equal to the switching point, an error report (Er4) will be indicated on the display and its value is deleted and its function is invalid (in the case that the window point and switching point out of adjustment).

The value is set in the same way as the switch point.

The window point is needed for process, in which monitoring of a certain measurement range is necessary.

Example: Switching point: 100 L/min; window point: 150 L/min;
hysteresis: -1 L/min

The electronic switches when 100 L/min is exceeded. If the measured value remains between 99 L/min (100-1) and 151 L/min (150+1), the contact will also remain in active switching condition (LED on). If it exceeds 151 L/min or is below 99 L/min the electronic switches back.

Switching behaviour

The following diagram clarifies the switching behaviour of the electronics. The contact closes (contact type: no) when exceeding below the switching point or when it under-runs the window point. It only opens again if the window point plus hysteresis is exceeded or if it drops below the switching point minus hysteresis. An **LED** indicates the switching condition of the switching point.

9.5.4 Filter

The filter function "**Filt**" forms a running average from the measured values. The following values can be set (see section 9.2 Settings):

1 / 2 / 4 / 8 / 16 / 32 / 64

They correspond to the number of samples used in the running average. The filter value determines the dynamic behaviour of the display value. The larger the adjusted value, the slower the display response. With a filter value of "1" the filter is switched off, i.e. the display value is equal to the unfiltered measured value.

The integrated step function detector reacts to a change of value corresponding to approx. 6.25% of the full scale value. As soon as a step function signal is detected, the instantaneous measured value is directly indicated in the display.

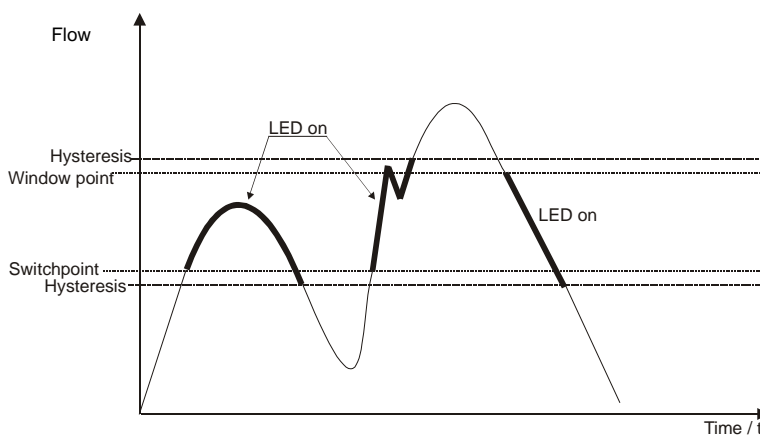
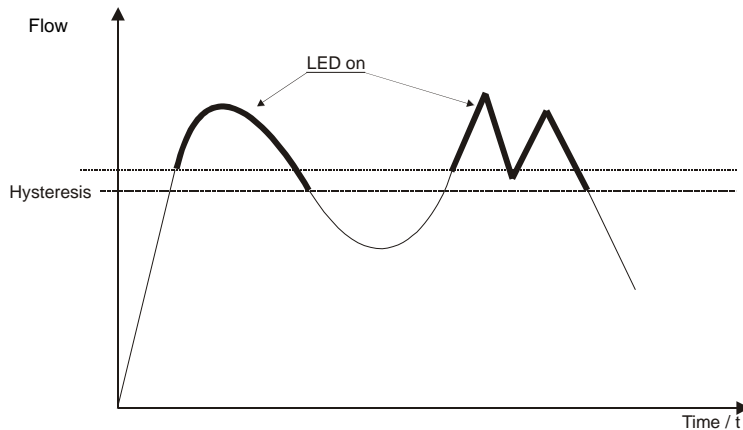

9.5.5 Contact type

The function of the transistor switching output is set in menu item "Con, Co1 or Co2". The switching function switches from

no - N/O contact to

nc - N/C to

Fr – frequency (only Con and Co1)

and back.

N/O contact: contact closes when switch point is exceeded

N/C contact: contact opens when switch point is exceeded

Frequency: frequency output is proportional to flow value

9.5.6 Current output

The current output is selected in menu items

"S-C" Start current indicated value < > 0(4) mA

"E-C" End current indicated value < > 20 mA

"SCS" Start current selection (0-20 mA or 4-20 mA).

The indicated value at which 0(4) mA flow is entered in menu item start current.

The indicated value at which 20 mA flow is entered in menu item end current.

9.5.7 Change code

The change code option "**CCo**" secures the unit against unauthorised tampering. If the code is different from 000, the user must input the code immediately after entering the adjustment mode.

10. Maintenance

The measurement device requires no maintenance if the measurement medium does not cause deposits. In order to avoid problems, we recommend the installation of a filter, such as the magnetic filter, model MFR.

If it is necessary to clean the sensor, the sensor can be rinsed with a suitable liquid. Fibre parts or large particles can be carefully removed with a cleaning cloth or similar.

Work on the electronics can only be performed by the factory, or the warranty is otherwise voided.

11. Technical Information

Range:	see table
Accuracy:	±2.0 % of f.s.
Repeat accuracy:	±1 % of f.s. (f.s. = full scale)
Measurement process:	magnetic inductive
Electrical conductivity:	min. 30 µS/cm
Mounting position:	in all directions, flow in direction of the arrow
Inlet / outlet:	3 x DN / 2 x DN
Media temperature:	-20...+80 °C (max. +60 °C with PVC-connection set)
Ambient temperature:	-10...+60 °C
Max. pressure:	10 bar
Max. pressure loss:	max. 0.25 bar at f.s.
Max. medium viscosity:	20 cSt ≤ G1"
Max. medium viscosity:	70 cSt ≥ G1½"

Wetted parts

Sensor housing:	PPS or PVDF, fibreglass-reinforced
Connection set:	PVC-glue connection or hose connection, weld-on ends st. st. 1.4404
Electrodes:	st. st. 1.4404 or Hastelloy C4
Seal:	NBR, FPM or FFKM
Response time t_{90} :	approx. 1 s
Protection:	IP 65

Connection/Ranges

Connection	Inside diameter [DN]	Flow velocity at f.s.	Measuring range
G ½ male	5 mm	approx. 0,45 m/s	10...500 mL/min
		approx. 0,9 m/s	0,05...1,0 L/min
		approx. 2,7 m/s	0,16...3,2 L/min
G ¾ male	10 mm	approx. 2,2 m/s	0,5...10,0 L/min
		approx. 3,5 m/s	0,8...16,0 L/min
G 1 male	15 mm	approx. 3,0 m/s	1,6...32,0 L/min
		approx. 4,7 m/s	2,5...50,0 L/min
G 1½ male	20 mm	approx. 3,3 m/s	3,2...63 L/min
		approx. 5,3 m/s	5,0...100 L/min
G 2 male	32 mm	approx. 3,3 m/s	8...160 L/min
		approx. 6,6 m/s	16...320 L/min
G 2¾ male	54 mm	approx. 3,6 m/s	25...500 L/min
		approx. 5,1 m/s	35...700 L/min

Weight Sensor

Model	PPS	PVDF
MIK-...08/10/15 (1/2")	approx. 180 g	approx. 210 g
MIK-...20/25 (3/4")	approx. 190 g	approx. 225 g
MIK-...30/35 (1")	approx. 270 g	approx. 325 g
MIK-...50/55 (1 1/2")	approx. 410 g	approx. 500 g
MIK-...60/65 (2")	approx. 560 g	approx. 610 g
MIK-...80/85 (2 3/4")	approx. 1200 g	approx. 1370 g

Weight Electronics

Model	Weight
MIK-...F3x0 MIK-...S30x MIK-...Lxx3	approx. 80 g
MIK-...C3xx	approx. 300 g
MIK-...Exxx MIK-...Gxxx	approx. 250 g

Total weight = weight sensor + weight electronics

MIK-...F300, MIK-...F390

Impulse output: PNP, Open Collector, max. 200 mA
500 Hz at f.s. (...F300)
50...1000 HZ at f.s. (...F390)
factory set as per customer request

Power supply: 24 V_{DC} ± 20 %

Power consumption: 60 mA

Electrical connection: plug M12x1

Measuring range overflow: F_{out} approx. 2 kHz up to 105% of f.s.

MIK-...S300, MIK-...S30D

Display: duo-LED for switch status

Switching output (...S300): relay SPDT, max. 1 A/30 V_{DC}

Switching output (...S30D): active 24 V_{DC}, , N/C and N/O

Switch point: 10...90 % f.s. in 10 %-steps
that can be configured by the
customer using a rotary encoder switch

Power supply: 24 V_{DC} ± 20 %

Power consumption: 80 mA

Electrical connection: plug M12x1, 5-pin

Measuring range overflow: flash of the DUO-LED (red/green)
up to 105 % of f.s.

MIK-...L303; MIK-...L343

Output: 0(4)-20 mA, 3-wire

Max. load: 500 Ω

Power supply: 24 V_{DC} ± 20 %

Power consumption: 80 mA

Electrical connection: plug M12x1

Measuring range overflow: I_{out} approx. 20,5 mA up to 103 % of f.s.

MIK-...L443 (usage with AUF-3000)

Output: 4-20 mA, 3-wire

Max. load: 500 Ω

Power supply: 24 V_{DC} ± 20 %

Power consumption: 80 mA

Electrical connection: plug DIN 43650

Measuring range overflow: I_{out} approx. 20,5 mA up to 103 % of f.s.

MIK-...C3xx (Compact electronics)

Display:	3-digit LED
Analogue output:	(0)4...20 mA adjustable (only MIK-...C34x),
Max. load:	500 Ω
Switching output:	1(2) semiconductor PNP or NPN, set at factory, max. 300 mA
Contact function:	N/C, N/O, frequency, programmable (frequency output not calibrated, frequency at f.s. approx. 1100-1600 Hz)
Setting:	with 2 buttons
Power supply:	24 V _{DC} \pm 20 %, 3-wire
Power consumption:	approx. 120 mA
Electrical connection:	plug M12x1

MIK-...Exxx (Counter electronics)

Display:	LCD, 2x8 digit, illuminated total, part and flow quantities, units selectable
Quantity meter:	8-digit
Analogue output:	(0)4...20 mA adjustable
Load:	max. 500 Ω
Switching output:	2 relays, max. 30 V _{AC/DC} /2 A/60 VA
Settings:	via 4 buttons
Functions:	reset, MIN/MAX memory, flow monitor, monitoring for part and total quantity, language
Power supply:	24 V _{DC} \pm 20 %, 3-wire
Power consumption:	approx. 150 mA
Electrical connection:	cable connection or M12 plug
<i>more technical details see data sheet ZED in the brochure Z2</i>	

MIK-...Gxxx (Dosing electronics)

Display:	LCD, 2x8 digit, illuminated, dosing, total and flow quantity, units selectable
Quantity meter:	8-digit
Dosage:	5-digit
Analogue output:	(0)4...20 mA adjustable
Load:	max. 500 Ω
Switching output:	2 relays, max. 30 V _{AC/DC} /2 A/60 VA
Settings:	via 4 buttons
Functions:	dosing (relay S2), start, stop, reset, fine dosing, correction amount, flow switch, total quantity, language
Power supply:	24 V _{DC} \pm 20 %, 3-wire
Power consumption:	approx. 150 mA
Electrical connection:	cable connection or M12 plug
<i>more technical details see data sheet ZED in the brochure Z2</i>	

12. Order Codes

Order details (Example: MIK-5NA 10 A F300)

Model	Range	Connection set	Electronics
MIK-5NA... = PPS-housing, NBR-seal, st. st.- electrode	..08.. = 10...500 mL/min, G ½	..A.. = without ¹⁾ ..P.. = PVC-hose connection ..E.. = st. st. weld-on ends	frequency output ..F300 = M12-plug, 500 Hz ..F390 = M12-plug, 50...1000 Hz ²⁾ switching output ..S300 = relay, M12-plug ..S30D = active 24 VDC, M12-plug
	..10.. = 0.05...1.0 L/min, G ½		
	..15.. = 0.16...3.2 L/min, G ½		
MIK-5VA... = PPS-housing, FPM-seal, st. st.-electrode	..20.. = 0.5...10.0 L/min, G ¾	..A.. = without ¹⁾ ..K.. = PVC-glue connection ..P.. = PVC-hose connection ..E.. = st. st. weld-on ends	analogue output ..L303 = M12-plug, 0-20 mA ..L343 = M12-plug, 4-20 mA ..L443 = DIN-plug, 4-20 mA compact electronics ⁴⁾ ..C30R = 2 x Open Coll. PNP ..C30M = 2 x Open Coll. NPN ..C34P = 0(4)-20 mA, 1 x Open Coll. PNP ..C34N = 0(4)-20 mA, 1 x Open Coll. NPN
	..25.. = 0.8...16.0 L/min, G ¾		
MIK-5NC... = PPS-housing, FPM-seal, Hastelloy®-electrode	..30.. = 1.6...32.0 L/min, G 1	..A.. = without ¹⁾ ..K.. = PVC-glue connection ..P.. = PVC-hose connection ..E.. = st. st. weld-on ends	counter electronics ⁴⁾ ..E11R = LCD, 0-10 V, 2 x relay, 24 V _{DC} , 1 m cable ..E14R = LCD, 0(4)-20 mA, 2 x relay, 1.5 m cable ..E34R = LCD, 0(4)-20 mA, 2 x relay, M12-plug ..E94R = LCD, 0(4)-20 mA, 2 x relay, cable >1.5 m ³⁾
	..35.. = 2.5...50.0 L/min, G 1		
MIK-5VC... = PPS-housing, FPM-seal, Hastelloy®-electrode	..50.. = 3.2...63 L/min, G 1½	..A.. = without ¹⁾ ..K.. = PVC-glue connection ..E.. = st. st. weld-on ends	dosing electronics ⁴⁾ ..G14R = LCD, 0(4)-20 mA, 2 x relay, 1.5 m cable ..G34R = LCD, 0(4)-20 mA, 2 x relay, M12-plug ..G94R = LCD, 0(4)-20 mA, 2 x relay, cable >1.5 m ³⁾
	..55.. = 5.0...100 L/min, G 1½		
MIK-6FT... = PVDF-housing, FFKM-seal, Tantalum-electrode	..60.. = 8...160 L/min, G 2	..A.. = without ¹⁾ ..K.. = PVC-glue connection ..E.. = st. st. weld-on ends	
	..65.. = 16...320 L/min, G 2		
	..80.. = 25...500 L/min, G 2¾		
	..85.. = 40...800 L/min, G 2¾		

¹⁾ Incl. frontal gaskets (2 pc. o-rings)

²⁾ Please specify frequency at full scale in clear text while ordering

³⁾ Please specify cable length in clear text.

⁴⁾ Please specify flow direction in clear text.

13. Dimensions

Model	G	L1	L2	L3	L4	L5	L6	H1	H2
MIK-xxx08A/10A/15A	G 1/2	118	90	14	46	58	36	43	28
MIK-xxx20A/25A	G 3/4	112	90	16	46	58	36	43	28
MIK-xxx30A/35A	G 1	126	90	18	46	58	36	49,5	29,5
MIK-xxx50A/55A	G 1 1/2	134	90	22	68	80	36	65,6	31,5
MIK-xxx60A/65A	G 2	138	90	24	68	80	36	72	36
MIK-xxx80A/85A	G 2 3/4	202	150	26	96	110	75	104	52

MIK-...F3x0; MIK-...S30x; MIK-...L3x3

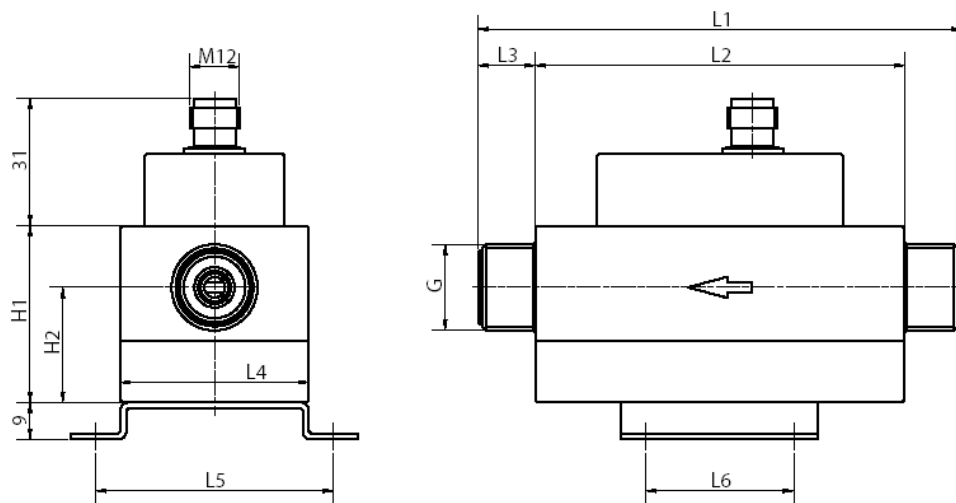

MIK-...L443

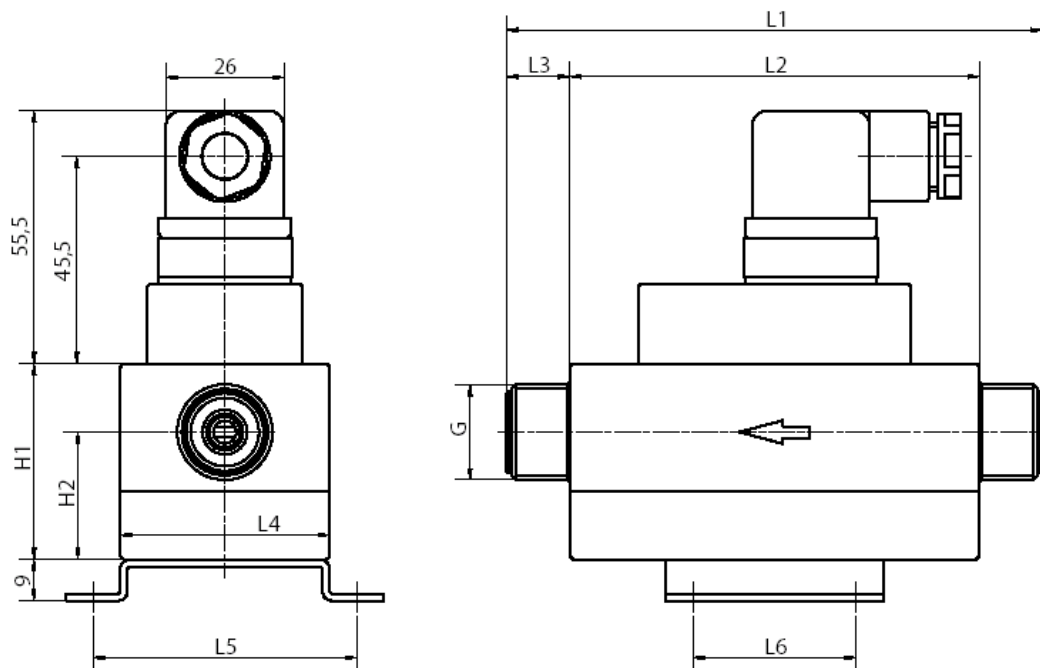

MIK-...C3xx

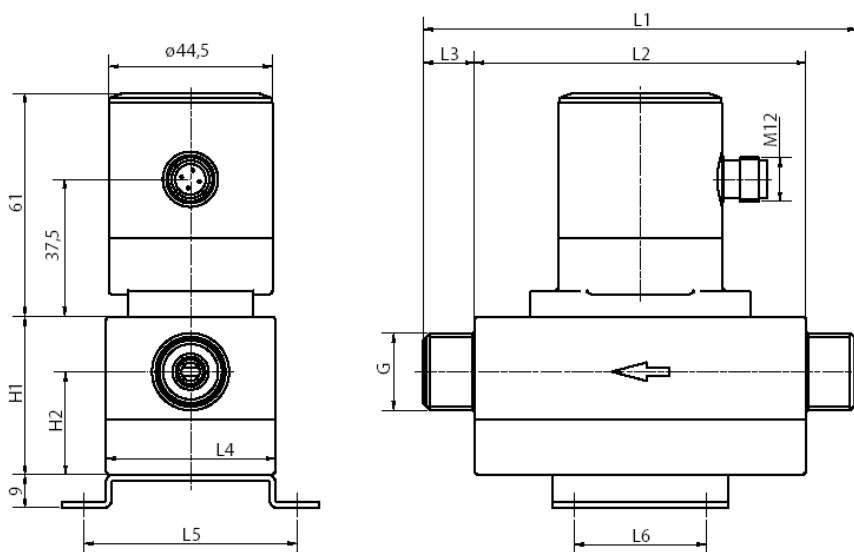

MIK-...Ex4R, MIK-...Gx4R

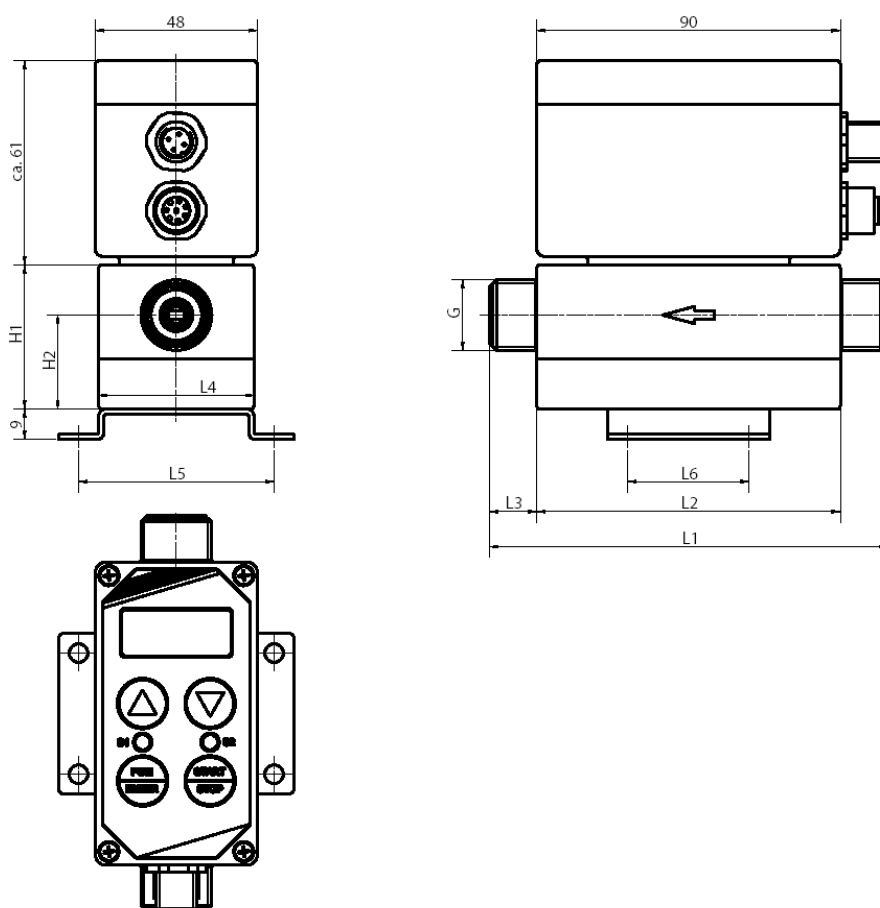

Dimensions Connection set PVC-gluе connection

G	Ø D1	Ø D2	Ø D3	L1	L2
G 1/2	not available				
G 3/4	35	16	10,5	21	14
G 1	43	20	15	23	16
G 1 1/2	60	32	26	27	22
G 2	74	40	33	30	26
G 2 3/4	103	63	54	38	38

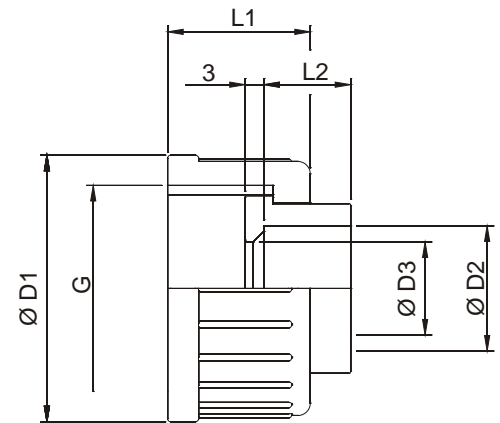

Dimensions Connection set PVC-hose connection

G	Ø D1	Ø D2	L
G 1/2	14	12	56
G 3/4	18	16	60
G 1	22	20	67
G 1 1/2	not available		
G 2	not available		
G 2 3/4	not available		

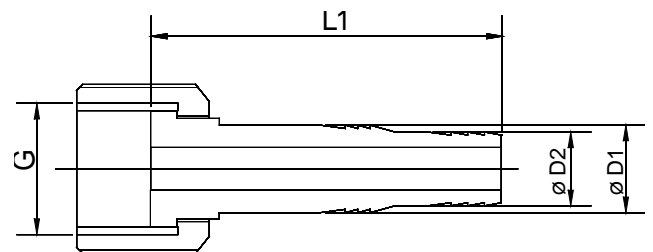

Dimensions Connection set st. st. weld-on-ends

G	SW	L	Ø D1	Ø D2
G 1/2	24	45	10,2	5
G 3/4	32	45	13,5	10
G 1	41	45	19	15
G 1 1/2	55	60	25	20
G 2	70	60	38	32
G 2 3/4	90	60	60,3	54

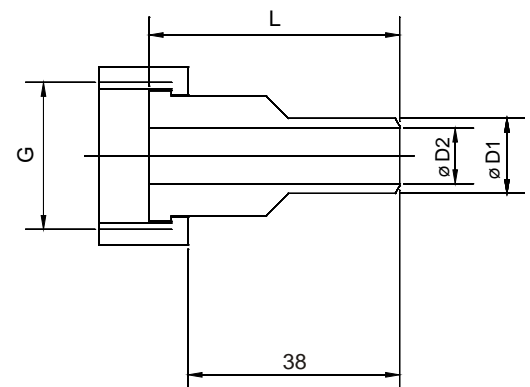

14. Disposal

Note!

- Avoid environmental damage caused by media-contaminated parts
- Dispose of the device and packaging in an environmentally friendly manner
- Comply with applicable national and international disposal regulations and environmental regulations.

Batteries

Batteries containing pollutants are marked with a sign consisting of a crossed-out garbage can and the chemical symbol (Cd, Hg, Li or Pb) of the heavy metal that is decisive for the classification as containing pollutants:

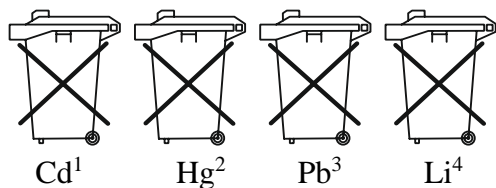

1. „Cd" stands for cadmium
2. „Hg" stands for mercury
3. „Pb" stands for lead
4. „Li" stands for lithium

Electrical and electronic equipment



15. EU Declaration of Conformance

We, KOBOLD Messring GmbH, Hofheim-Ts, Germany, declare under our sole responsibility that the product:

Compact Magnetic-Inductive Flow Meter Model: MIK-...

to which this declaration relates is in conformity with the standards noted below:

EN 61326-1: 2013

Electrical equipment for measurement, control and laboratory use - EMC requirements - Part 1: General requirements

EN 61010-1: 2011

Safety requirements for electrical measuring-, control- and laboratory instruments

EN IEC 63000:2018

Technical documentation for the assessment of electrical and electronic products with respect to the restriction of hazardous substances

Also, the following EC guidelines are fulfilled:

2014/30/EU	EMC Directive
2011/65/EU	RoHS (category 9)
2015/863/EU	Delegated Directive (RoHS III)



H. Peters
General Manager

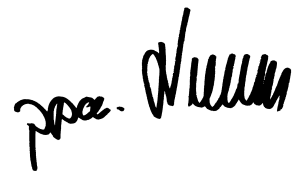

M. Wenzel
Proxy Holder

Hofheim, 27 Jan. 2021

16. UK Declaration of Conformity

We, KOBOLD Messring GmbH, Hofheim-Ts, Germany, declare under our sole responsibility that the product:

Compact Magnetic-Inductive Flow Meter Model: MIK-...

to which this declaration relates is in conformity with the standards noted below:

BS EN 61326-1:2013

Electrical equipment for measurement, control and laboratory use. EMC requirements. General requirements

BS EN 61010-1:2010

Safety requirements for electrical equipment for measurement, control, and laboratory use. General requirements

BS EN IEC 63000:2018

Technical documentation for the assessment of electrical and electronic products with respect to the restriction of hazardous substances.

Also, the following UK guidelines are fulfilled:

S.I. 2016/1091

Electromagnetic Compatibility Regulations 2016

S.I. 2012/3032

The Restriction of the Use of Certain Hazardous Substances in Electrical and Electronic Equipment Regulations 2012



H. Peters
General Manager



M. Wenzel
Proxy Holder

Hofheim, 27 Jan. 2021