

Overview



ST-H transducers use ultrasonic technology to measure level in chemical storage and liquid tanks.

Benefits

- Can be mounted on a narrow standpipe
- Immune to corrosive and harsh environments
- Integral temperature sensor

Application

The narrow design of the ST-H allows the transducer to be mounted on a narrow standpipe. When mounted correctly, it is completely protected from the process and can even be used in harsh, corrosive environments.

During operation, the ultrasonic transducer emits acoustic pulses in a narrow beam perpendicular to the transducer face. The level transceiver measures the propagation time between pulse emission and reception of the echo to calculate the distance from the transducer to the material. Variations in sound velocity due to changes in temperature within the permissible range are automatically compensated by the integral temperature sensor.

- Key Applications: chemical storage, liquid tanks

Technical specifications

Mode of operation	
Measuring principle	Ultrasonic transducer
Input	
Measuring range	0.3 ... 10 m (1 ... 33 ft)
Output	
Frequency	44 kHz
Beam angle	12°
Accuracy	
Temperature compensation	Compensated by integral temperature sensor
Rated operating conditions	
Pressure	Normal atmospheric pressure
Ambient conditions	
Ambient temperature	-20 ... +60 °C (-5 ... +140 °F) (ATEX approved model) -40 ... +73 °C (-40 ... +163 °F) (CSA/FM approved model)
Design	
Weight ¹⁾	1.4 kg (3 lb)
Material (enclosure)	Base and lid made of ETFE or PVDF (epoxy fitted joint) ²⁾
Process connection	2" NPT [(Taper), ANSI/ASME B1.20.1], R 2" [(BSPT), EN 10226] or G 2" [(BSPP), EN ISO 228-1]
Degree of protection	IP68
Cable connection	2-core shielded/twisted, 0.519 mm ² (20 AWG), PVC sheath
Cable (max. length)	365 m (1 200 ft) with RG 62 A/U coaxial cable
Options	
Flange adapter	3" Universal (fits DN 65, PN 10 and 3" ASME)
Certificates and approvals	
CE, CSA Class I, II, III, Div. 1, Groups A, B, C, D, E, F, G T3 (ETFE only), FM Class I, II, Div. 1, Groups C, D, E, F, G T4A, ATEX II 2G / INMETRO Ex mb IIC T5 Gb, RCM, KCC	

¹⁾ Approximate shipping weight of transducer with standard cable length

²⁾ When measuring chemicals, check compatibility of ETFE or PVDF and epoxy, or mount joint external to process.

Level Measurement

Continuous level measurement
Ultrasonic transducers

ST-H

Selection and Ordering data	Article No.
EchoMax ST-H ultrasonic transducer Level measurement in chemical storage and liquid tanks. The narrow design of the ST-H allows the transducer to be mounted on a 2 inch standpipe. Measuring range: min. 0.3 m (1 ft), max. 10 m (33 ft). ↗ Click on the Article No. for the online configuration in the PIA Life Cycle Portal.	7ML1100-
	A 0
	0
	1
	2
	3
	4
	5
	A
	B
	C
	D
	E
Process connection ETFE, 2" NPT [(Taper), ANSI/ASME B1.20.1] ETFE, R 2" [(BSPT), EN 10226] ETFE, G 2" [(BSPP), EN ISO 228-1] PVDF copolymer, 2" NPT [(Taper), ANSI/ASME B1.20.1] PVDF copolymer, R 2" [(BSPT), EN 10226] PVDF copolymer, G 2" [(BSPP), EN ISO 228-1]	
Cable length 5 m (16.40 ft) 10 m (32.81 ft) 30 m (98.43 ft) 50 m (164.04 ft) 100 m (328.08 ft)	
Approvals CE, FM Class I, II, Div. 1, Groups C,D,E,F,G T4A ³⁾ ATEX 2G / INMETRO Ex mb IIC T5 Gb, RCM, KCC CSA Class I, II, III, Div. 1, Groups A,B,C,D,E,F,G T3 ¹⁾ CE, ATEX 2G / INMETRO Ex mb IIC T5 Gb, RCM, KCC ²⁾	
	2
	3
	4
Operating Instructions Multi-language Note: The Operating Instructions should be ordered as a separate line item on the order. All literature is available to download for free, in a range of languages, at http://www.siemens.com/processinstrumentation/documentation	Article No. A5E43390688

¹⁾ Available with Process connection options 0 ... 2 only

²⁾ Available with Process connection options 3 ... 5 only

³⁾ Not suitable for Ketone, Hexane, Ester or Ethyl Acetate atmospheres

Selection and Ordering data	Order code
Further designs Please add "-Z" to Article No. and specify Order code(s). Acrylic coated, stainless steel tag [13 x 45 mm (0.5 x 1.75 inch)]: Measuring-point number/identification (max. 16 characters) specify in plain text	Y17
Accessories Universal box bracket, mounting kit 3" ASME, DN 65 PN 10, JIS 10K 3B ETFE flange adapter for 2" NPT 3" ASME, DN 65 PN 10, JIS 10K 3B ETFE flange adapter for 2" BSPT Easy Aimer 2, aluminum, NPT with ¾" x 1" PVC coupling Easy Aimer 2, aluminum with M20 adapter and 1" and 1½" BSPT aluminum couplings Easy Aimer 304, NPT with 1" stainless steel coupling Easy Aimer 304, with M20 adapter and 1" and 1½" BSPT 304 stainless steel couplings Plastic adapter 1" NPT Plastic adapter 1" NPT/M20	Article No. 7ML1830-1BK 7ML1830-1BT 7ML1830-1BU 7ML1830-1AQ 7ML1830-1AX 7ML1830-1AU 7ML1830-1GN 7ML1930-1FX 7ML1830-1EF

Dimensional drawings

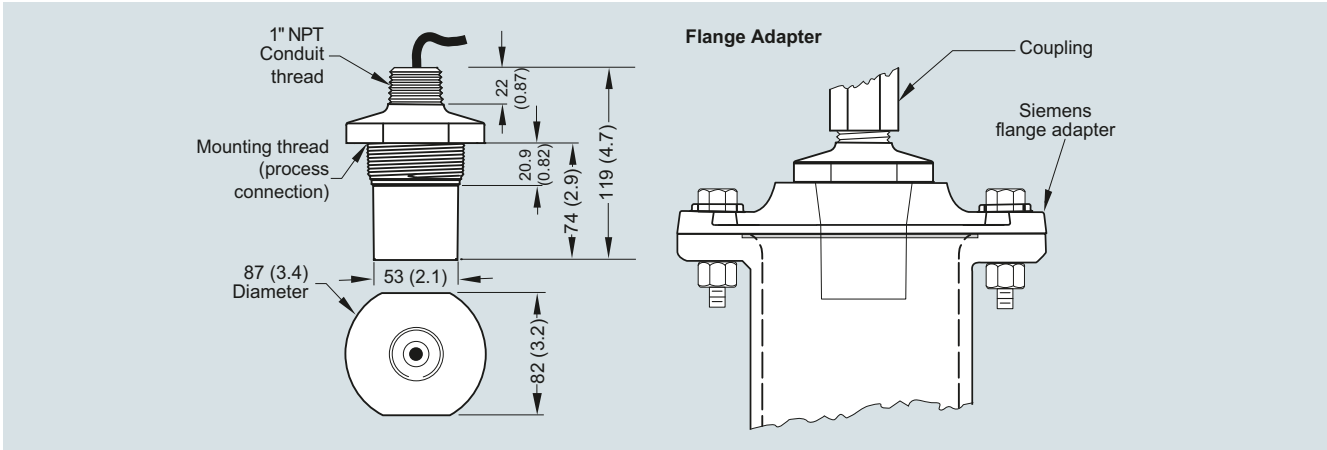

ST-H ultrasonic transducer, dimensions in mm (inch)

Circuit diagrams

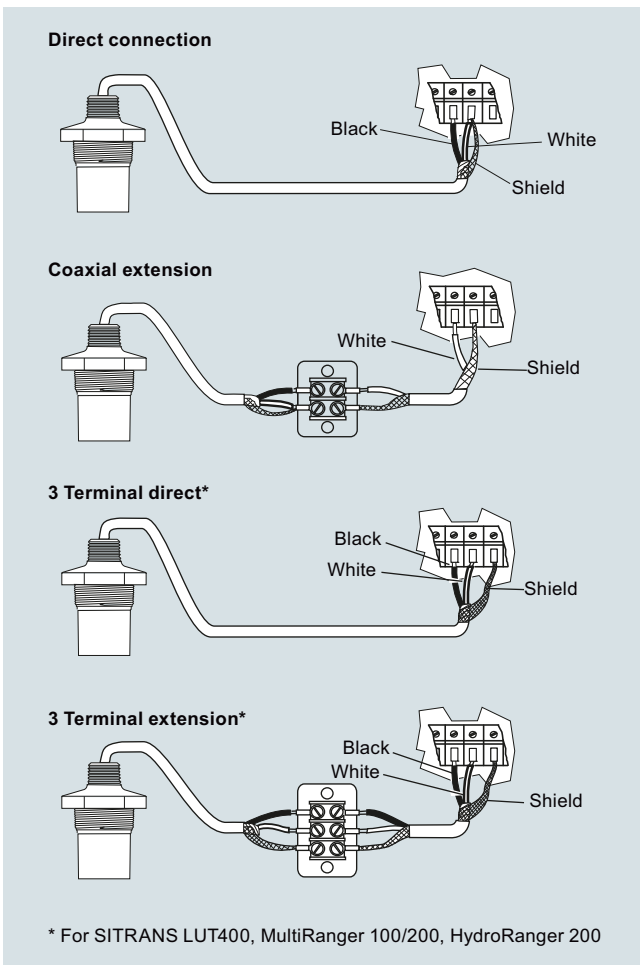

ST-H ultrasonic transducer connections